



LEWIS POULTRY HOUSEKEEPER OWNER / OPERATOR MANUAL



MODEL # HK-5LP HOUSEKEEPER

FROM: SERIAL # 9419

Manufactured by: **LEWIS BROTHERS MANUFACTURING, INC.**

Post Office Box 146
Baxley, GA 31513
Tel: (912) 367-4651
Fax: (912) 367-3958

10-19-2021

INTRODUCTION

All Lewis Brothers equipment is manufactured under stringent production and quality assurance procedures prior to preparation for shipment. A final quality check is performed on all equipment before shipping.

The best equipment is only as good as its operation and management. Sound operation and good preventive maintenance practices are essential to efficient performance of your Lewis Poultry Housekeeper.

Questions on parts and service for the equipment covered in this manual should be referred to the local dealer from whom the equipment was purchased, or the nearest Lewis Brothers Dealer.

We sincerely thank you for purchasing Lewis Brothers equipment.

TABLE OF CONTENTS

INTRODUCTION	2
SAFETY	4
Owner's And Operator's Responsibility	5
General Precautions	6
LIMITED WARRANTY	8
SPECIFICATIONS	10
SETUP AND OPERATION	12
Machine Setup	13
Tractor Settings	13
Attachment to Tractor	13
Operating Instructions	15
Spreader Installation	18
Turkey Operations	21
Towing and Transport	22
Total Clean Out	24
STORAGE	26
MAINTENANCE	28
Chain Adjustments	29
Lubrication and Hydraulic Oil	37
Tires	38
Repairs	38
Decals	39
PARTS	42-62

SAFETY

OWNER'S AND OPERATOR'S RESPONSIBILITY

This manual is intended for use with your Lewis Poultry Housekeeper. Extra effort has been made to provide for safe operation of this equipment. This manual as well as the safety decals placed on the equipment is part of that effort. Your new Housekeeper should perform the various functions for which it was designed if it is maintained, adjusted to your specific conditions, and operated correctly.

It is the responsibility of the owner and every operator of this equipment to read and understand this manual before initial startup, before each season, before performing service or maintenance tasks and prior to storing the equipment. Each employee who will work on or around this equipment should be instructed in how to do so safely.

It is important to understand the operational methods and safety issues mentioned in this manual. Lewis Brothers cannot anticipate all conceivable ways service and operational functions might be performed and of the possible hazardous consequences of such. Anyone using or servicing this equipment must first satisfy themselves that their chosen methods do not jeopardize the safety of themselves, others, or the equipment.

Read the warranty on page 9. The purchaser is required to fill out and return the registration card supplied with this owner's manual within ten (10) days of purchase to Lewis Brothers Manufacturing to be eligible for warranty coverage.

Genuine Lewis replacement parts will insure the durability and long life of your Housekeeper. Lewis repair parts and optional equipment should be ordered through your Lewis Brothers' Dealer.

Operators should thoroughly inspect the Housekeeper before and after each use. All chains and bearings should be properly lubricated as specified, and any worn or damaged parts repaired or replaced. Failure to repair or replace worn parts could result in damage or excess wear to other parts.

GENERAL PRECAUTIONS

- **MAKE SURE** everyone is clear of the equipment before starting the tractor's engine and while equipment is under operation.
- **DO NOT** allow anyone to ride on this equipment.
- **KEEP** hands, feet, hair and clothing away from all moving parts. Do not wear loose clothing while operating equipment, as this may present an entanglement hazard.
- **DRIVE** the pulling tractor at speeds compatible with conditions and good safety practices. This is especially important when operating over rough ground, on slopes, crossing ditches or while turning. Tip over may occur if a safe speed is not maintained during operation.
- **STOP** the tractor's engine and relieve any hydraulic pressure by actuating all hydraulic valves in both directions before disconnecting any part of the hydraulic system.
- **MAKE SURE** hitch components are attached securely before operating or transporting.
- **USE** flashing warning lights when on highways, except where prohibited by law.

- **STOP** tractor engine before leaving operator's position to adjust, lubricate, clean or unclog machine.
- **KEEP** all shields in place.
- **DANGER!** Chock wheels and block up head of machine securely prior to working under machine. Failure to do so may result in serious injury or death.
- **MAXIMUM** towing speed is 25 MPH.
- **OBSERVE** all safety decals located on machine. Should any safety decal become damaged unreadable, or lost, **REPLACE IT IMMEDIATELY**. New decals may be obtained from your Lewis Brothers' dealer.
- **WEAR** dust respirator at all times while using this machine (3M part # 8710 is recommended).
- **R.O.P.S.** use ROPS and seat belts whenever and wherever applicable. If your tractor has a foldable ROPS, fold it down only when absolutely necessary and fold it up and lock it again as soon as possible. Do not wear seat belt when the ROPS is folded. We strongly recommend the use of ROPS and seat belts in almost all applications.

WARRANTY

LIMITED WARRANTY

Lewis Brothers Manufacturing, Inc. (hereinafter referred to as "LBM") warrants each item of new equipment manufactured by LBM to be free from defects in material and workmanship under normal use and service.

The obligation of LBM under this LIMITED WARRANTY is limited to repair or replacement, as LBM may elect, of any parts that prove, in LBM's judgment, to be defective in material and workmanship within the first twelve (12) months after the date of invoice to the original purchaser. THIS LIMITED WARRANTY DOES NOT APPLY TO BELTS, HYDRAULIC HOSES, TIRES, AND OTHER SERVICE ITEMS, WHICH SHALL HAVE A NINETY (90) DAY WARRANTY.

THIS LIMITED WARRANTY WILL APPLY FOR (3) MONTHS ONLY WHEN THE UNIT IS USED IN A COMMERCIAL APPLICATION.

All warranty part repairs and replacements must be made by a certified LBM dealer. Any outside work or alterations made without written approval of LBM will render this LIMITED WARRANTY void.

LBM's obligation specifically excludes any liability for consequential damages, such as loss of profit, delays, expenses, damage to goods or property used in connection with or processed in or by the product sold, or damage to the product sold from whatever cause, whether or not such loss is due to negligence by LBM.

This LIMITED WARRANTY shall not apply to any item that has been operated in a manner not recommended by LBM.

No person is authorized to give any other warranties or to assume any other liability on behalf of LBM unless made in writing by Lewis Brothers Manufacturing, Inc.

THIS LIMITED WARRANTY IS IN LIEU OF AND REPLACES ALL OTHER WARRANTIES, EXPRESSED OR IMPLIED. WARRANTIES OF MERCHANTABILITY AND FITNESS FOR A PARTICULAR PURPOSE ARE EXCLUDED, AS ARE ALL OTHER REPRESENTATIONS TO THE USER-PURCHASER AND ALL OTHER OBLIGATIONS OR LIABILITIES, INCLUDING LIABILITY FOR INCIDENTAL AND CONSEQUENTIAL DAMAGES, ON THE PART OF LBM.

LEWIS BROTHERS MANUFACTURING, INC.

P.O. BOX 146 - BAXLEY, GA. 31513

FEBRUARY 1, 2007

SPECIFICATIONS

SPECIFICATIONS

Housekeeper Model # 5LP

Overall Working Height	66 inches
Overall Length	22 1/2 feet
Width (outside tires)	74 inches
Overall Width	83 inches
Throat	69 inches
Capacity	135 cubic ft
Weight (unloaded)	5800 lbs.
PTO Hydraulic Pump	22 GPM
Hydraulic Pressure @ 540 rpm	2350 PSI
Tire Pressure	50 PSI
Tire Size (Single Axle) (Tandem Axle)	12.5L X 16 9.5L X 15
Hydraulic Oil	AW-68
Oil Reservoir Capacity	30 GAL.
Tractor Horsepower required	60 HP
Tongue Weight (unloaded)	1350 lbs.

SETUP AND OPERATION

MACHINE SETUP

TRACTOR SETTINGS

The Lewis Poultry Housekeeper #5LP should be attached at the fixed drawbar for proper operation. If your tractor has an option of a 540 or 1000 rpm PTO, you should install the 540 shaft.

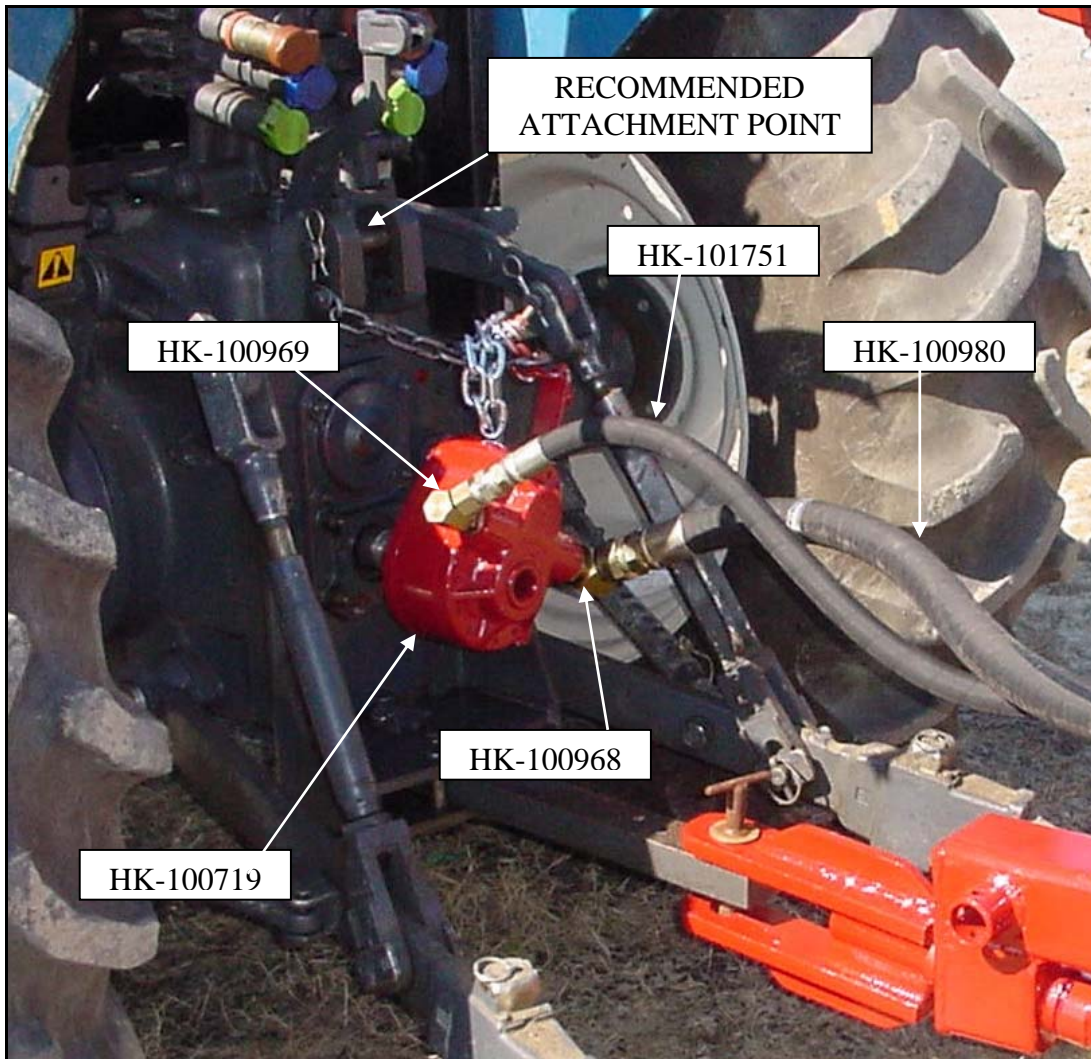

Figure 1

ATTACHING HOUSEKEEPER TO THE TRACTOR

Attach the Poultry Housekeeper to the tractor's fixed drawbar using a heavy-duty hitch pin. Next, attach the hydraulic pump to the tractor PTO shaft. Slide the pump onto the PTO shaft as far as possible. Secure its position by wrapping the chain on the torque arm around some portion of the tractor hitch which is secure and will

not allow the pump to slide off or spin once the PTO is engaged. A good place to chain the pump is around the top link pin. Always try to pull the pump from the PTO after it is chained into place. If the pump slides very far back on the shaft it is not snug enough. Take up another link on the chain and repeat the process again. Making this connection too tight may put excess pressure on the PTO shaft resulting in damage to pump or shaft. (See figure 1)

The tongue of the unit can be moved to the far right position so that the pickup head will be positioned closer to the poultry house wall. Before starting to clean out a house, the operator should decide whether to start next to the walls or in the middle of the house and set the tongue accordingly. Always set the tongue back to the center position when not cleaning next to the walls or a row of posts, and before leaving the house. (See Figure 2)

The main control valve should be adjusted so that it is easily accessible to the operator, but not so close that it will make contact with the tractor.

CAUTION! The Oil Supply Valve Handle must be in the horizontal position at all times during operation in order to supply full flow to the system. Be sure to check before engaging the pump. Failure to maintain this position will damage the pump.

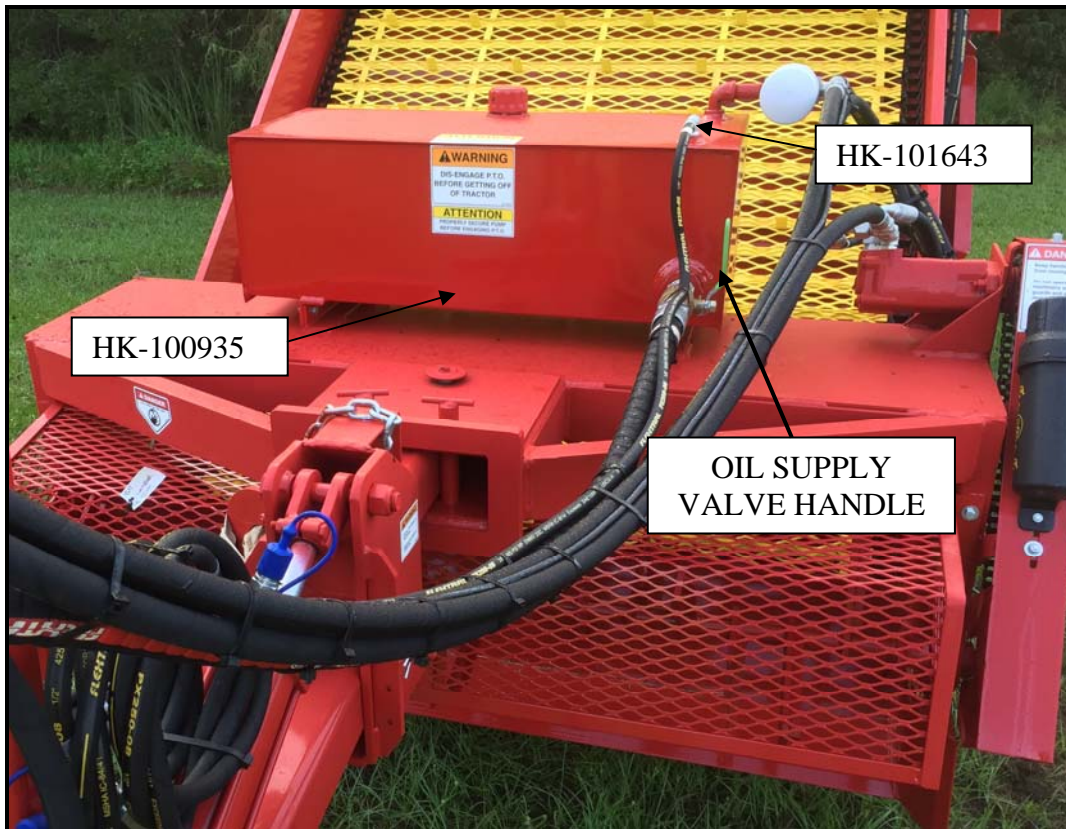

Figure 2

OPERATING INSTRUCTIONS

The Lewis Poultry Housekeeper is designed to be operated with the tractor PTO turning within a range of 500 to 540 RPM. 540 RPM is the most desirable speed and will produce the maximum flow and pressure from the pump. To put the machine into operation, first engage the PTO of the tractor and then pull the control valve handle forward. This should start the cylinder reel, loading conveyor and the leveling assembly into motion. Next, bring the PTO of the tractor up to speed.

The ground speed will depend on the particular operation being performed and the amount of material being removed from the floor of the house. Generally, first gear or 1 to 1-1/2 MPH is used for total clean out and removal of medium cake during sifting. Very heavy cake or excessive ground speed may cause litter to be pushed in front of the machine. The Poultry Housekeeper operates best at a depth of 3-4 inches. If litter or cake is deeper than four inches it is recommended that

two passes be made through the house to clean or sift the litter. In excessive cake the ground speed may be reduced to help sift the total cake in a single pass. Higher gears may be used when sifting where the litter does not exceed 3-4 inches and where cake is light.

Speeds of the drive components are very important to the performance of the Poultry Housekeeper. PTO speeds in the 500-540 ranges should be maintained at all times during operation.

The ability to shake the loading conveyor while sifting the litter is what makes the Lewis Poultry Housekeeper work so well. Shaking makes the separation process work by allowing the smaller particles to pass through the screens while the larger “cakes” are tumbled for a short time before being carried into the body. The gentle lifting and shaking process keeps wet litter and feathers from passing through the screens.

Setting and maintaining the proper blade depth is important for maximum performance. To properly set the depth, slowly lower the front of the Poultry Housekeeper into the litter with your tractor. Lift until the desired depth is reached. It may take some time to become accustomed to how deep the blade is running. By observing the blade and loading cylinder during operation, proper depth can be determined for the given conditions. In houses where uniform amounts of material will be removed, set the stops on the tractor lift. This will provide consistent blade depth each time the machine is raised or lowered. The body loads from front to rear, and although it is sometimes difficult to see the rear of the machine because of the dust, the operator will know the body is full when the leveling bars begin to kick litter into the air. When this occurs, move the control valve handle to the center position to disengage the conveyor. The load is now ready to be transported and unloaded at the desired site.

The body may be unloaded by spreading or by a quick dump method. If the spreading method is to be used, refer to the section on “Spreader Installation and Operation” on the following pages. To do a quick dump as in composting or stockpiling:

1. Make sure the bumper and spreader are not attached and that the hydraulic hoses are connected properly. Remove tailgate lock-down bolts and the tension springs from upper section of the tailgate. Store these in a secure place for later installation.
2. The center springs and pins should be installed between the upper and lower sections of the tailgate as shown in (figure 3). This will cause the tailgate to become rigid and function as one piece while litter is being transferred rearward. Failure to install these properly will result in improper unloading of litter.
3. Once you have reached the composting or unloading site, push the control valve lever to the rear and begin the unloading process. The unloading chain will drag the litter out the back of the machine. Forward movement of the machine may be necessary to allow for litter being discharged.
4. After all the litter has been discharged, pull away from the pile and move the control lever forward to the loading position This will engage the tailgate cylinder and cause the tailgate to return to the closed position. It is important to unload all the litter or the tailgate will not close properly. The machine is now ready to be re-loaded.

CAUTION: Never back the Lewis Poultry Housekeeper while the loading assembly is in the down position and in operation! Litter and other objects may be forced into the rear of the loading assembly and possibly cause the assembly to jam. Always lift the front of the machine or stop the assembly before backing the machine.

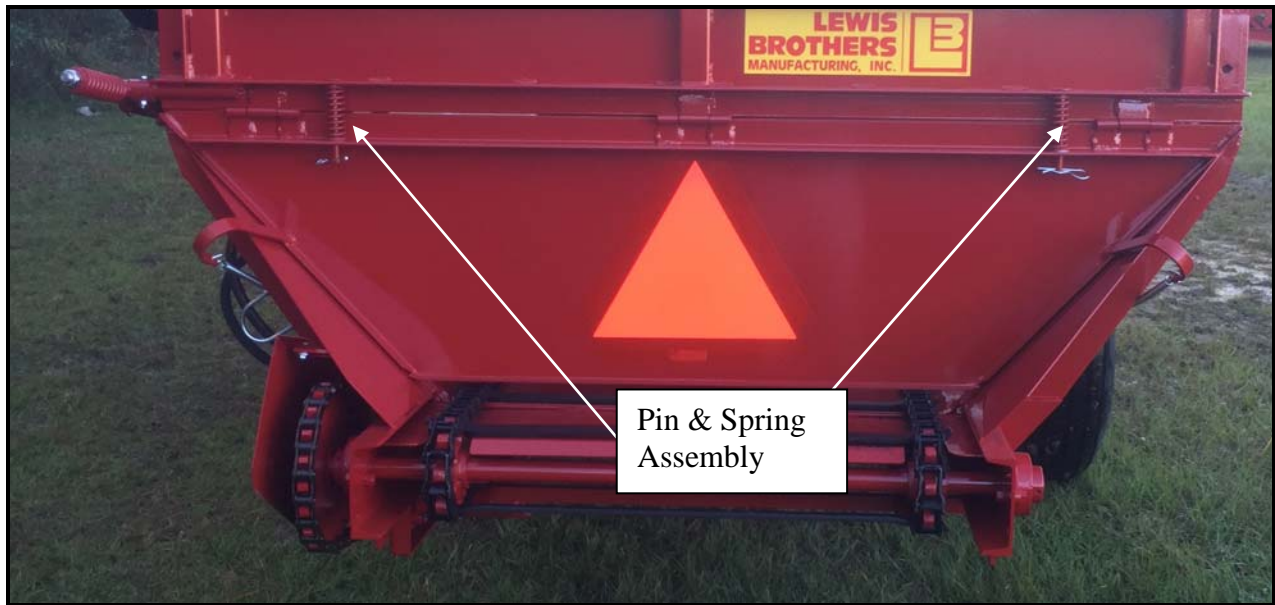

Figure 3

SPREADER INSTALLATION AND OPERATION

INSTALLATION

1. The spreader unit comes pre-assembled and is attached to the main frame of the Housekeeper using four 1/2x1-1/2 inch bolts.(see figure 4)
2. Locate the hydraulic 'quick-coupler' attached to the base end of the tailgate cylinder and uncouple the fittings from the coupling block (see fig. 5). Connect the two ends to the matching fittings on the hydraulic motor located on the spreader assembly.
3. Install the bumper and the diverter assembly.
4. Remove the pins and springs in the center section of the tailgate and store in a secure location.
5. Attach the lower tailgate tension springs from the tailgate to the frame

OPERATION

Two primary concerns when spreading litter are the amount being applied and the pattern of distribution. The settings for the discharge rate will vary depending on the consistency of the litter. The common setting for dry litter is position No. 5 on the control valve. The flow control valve may be increased or decreased depending on the volume of litter to be applied.

The distribution pattern is influenced by the location of the diverter attached to the rear bumper. Best results are achieved when the diverter is positioned at approximately 45 degrees. (See Figure 6)

Fresh litter may be spread in the house with the Housekeeper once the clean out process has been completed. Shavings may be loaded into the body of the Housekeeper with a front loading device or by picking up the shavings with the loading conveyor of the Housekeeper itself. If equipped with perforated bars, you will need to remove the shaker wheels and operate the Housekeeper in the slowest gear and speed.

The unloading and spreading process requires a lot of hydraulic capacity both in volume and pressure. It is not uncommon for low horsepower tractors to become heavily loaded during these operations. Slower speeds may be required if this situation occurs.

WARNING! Do not operate the spreader with anyone standing behind the machine. The material being discharged is traveling at a high rate of speed and could contain objects capable of causing serious personal injury.



Figure 4

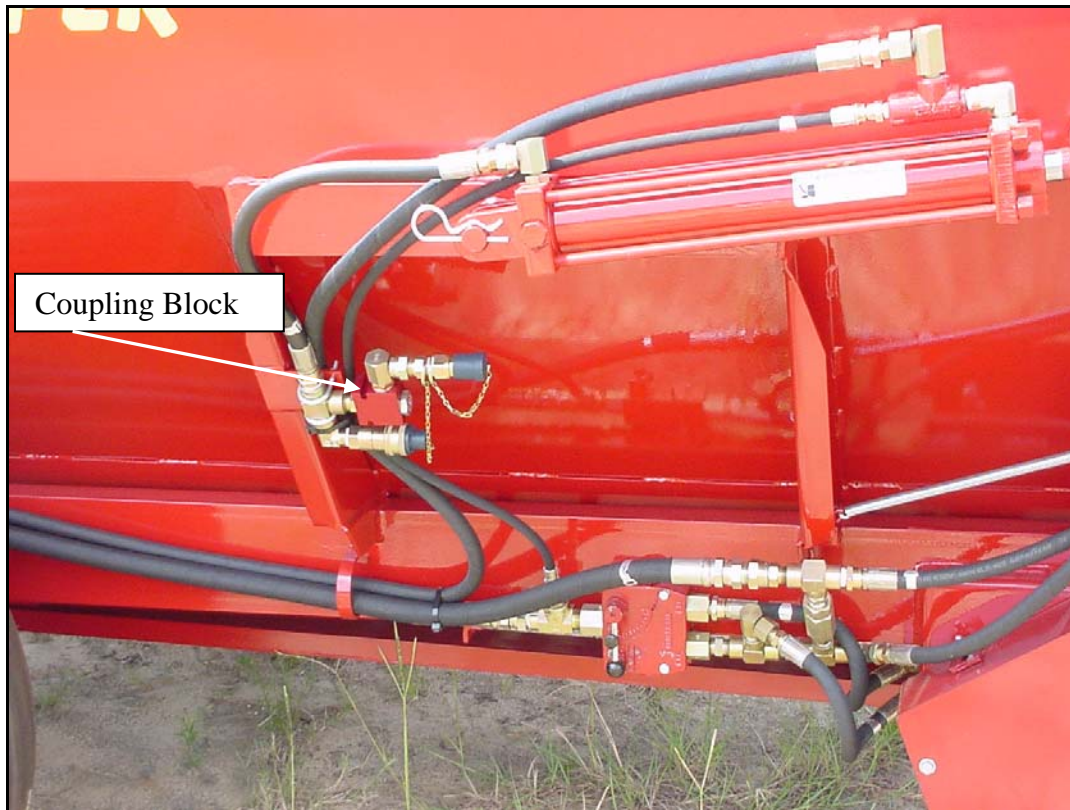

Figure 5

TURKEY OPERATIONS

When the Lewis Poultry Housekeeper is used in very heavy turkey cake, it may become necessary to slow the ground speed to 1/2 MPH. This works best because it is very difficult to cut through turkey litter due to the very large feathers present. Additionally, feathers may wrap around the blade and loading cylinder, causing litter to be pushed ahead of the machine. The following procedure must be followed to properly remove the feathers from the loading blade.

1. Stop the tractor.
2. Disengage control valve.
3. Back the tractor up with the head in the down position.
4. Stop the tractor.
5. Engage control valve to loading position.
6. Start tractor in a forward motion again.
7. All feathers are wiped from the loading blade and are then loaded into the body.

The wide head enables the Housekeeper to start from the walls and work towards the center of the house. There is little need to overlap since the head is as wide as the tire track. The floor is left smooth and ridge free.



Figure 6

TOWING AND TRANSPORTING

A tractor of sufficient weight and power is required to both pull and control a Lewis Brothers Housekeeper over the terrain in the given area of operation. A tractor with a minimum of 60 PTO hp is required for proper operation of the # 5LP Housekeeper. In order to have full control, your tractor must be able to maintain traction under all turf or surface conditions. Additional weights may be required to the front of the tractor to avoid unstable towing conditions.

If it becomes necessary to tow the Poultry Housekeeper behind a truck for extended distances the following is recommended. Secure the hydraulic pump with the torque bar chain on the tongue. (See figure 6A Tie up all hoses to prevent them from dragging or becoming damaged. Tongue weight for towing is approximately 1300 to 1500 lbs. The truck used for towing must be heavy enough to pull the Housekeeper, but more importantly must be equipped to safely stop under the additional load.



Figure 6A

The hitch height must provide a clearance of five to six inches below the blade of the Housekeeper after the Housekeeper has been attached to the towing vehicle.

Maximum caution should be maintained at all times when transporting the Lewis Housekeeper.

TOTAL CLEANOUT

The # 5LP Housekeeper is designed to give the operator total control over the amount of material removed during operation. This is done by adjusting the loading conveyor doors located on the underside of the conveyor assembly. (See Figure 6B) The operator can remove as much or as little litter as desired by simply rotating the conveyor doors to the desired position.



Figure 6B

The process of changing from a total caking or crusting operation must begin with the removal of the shaker rollers. These shaker rollers cause the loading chain to “shake” or shift the material and thus ensure that the separation process is completed. Start by removing one of the loading bars at the very top of the loading assembly. Next, slowly rotate the chain until the gap in the chain stops directly over the shaker rollers. (See Figure 6C) The shaker rollers may now be removed with a wrench. Once the shaker assemblies have been removed and the bars replaced, all of the conveyor doors may be closed for the total clean out operation. Reverse this procedure when replacing the shaker rollers.



Figure 6C

The four conveyor doors are used to regulate the amount of litter that is returned to the house floor.

Open the doors by placing a 1-1/8 wrench down on the hex head door holder. (Figure 6D) Press down on the wrench to relieve pressure on the door holder while at the same time removing the hairpin. This will allow the door to drop down into the open position. Repeat this procedure for the other side of the door. Open as many doors as needed to return the desired amount of material to the house floor.



Figure 6D

To return the door to the closed position, reach under the door and pick it up until the door closes. While holding the door closed with the pressure from the wrench, re-install the hairpin. The door will now remain closed.

STORAGE

STORAGE

After each use, the Poultry Housekeeper should be washed down thoroughly removing all litter, inside and out. After washing, treating with a disinfectant is recommended in order to kill any remaining bacteria. The next step is treating the machine with soluble oil to protect it from rust and corrosion. One product that meets these requirements is called LPS#3. You may find this or other similar products at your Lewis Poultry Housekeeper Dealer; tractor dealerships or farm supply stores. It is important to remember that all chains must be properly lubricated after each use and especially before storage.

CAUTION: When washing the Housekeeper, never allow a high-pressure water stream to come in contact with bearings or idler seals. Water can be forced into the bearing and will cause premature failure.

Check all safety decals and make any necessary replacements. Decals may be obtained from your Lewis Dealer.

MAINTENANCE

MAINTENANCE

CHAIN ADJUSTMENTS

Periodical adjustments may be necessary to the conveyor chains, drive chains and leveling assembly chains.

With the operator in front of the Housekeeper and facing towards the machine, the **loading cylinder drive chain** will be located on the right side of the machine. As it wears and stretches from use, the idler sprocket should be adjusted to remove any slack.

Proper tension on the chain should allow for approximately 1 inch of movement in the tightness of chain. (See figure 7)

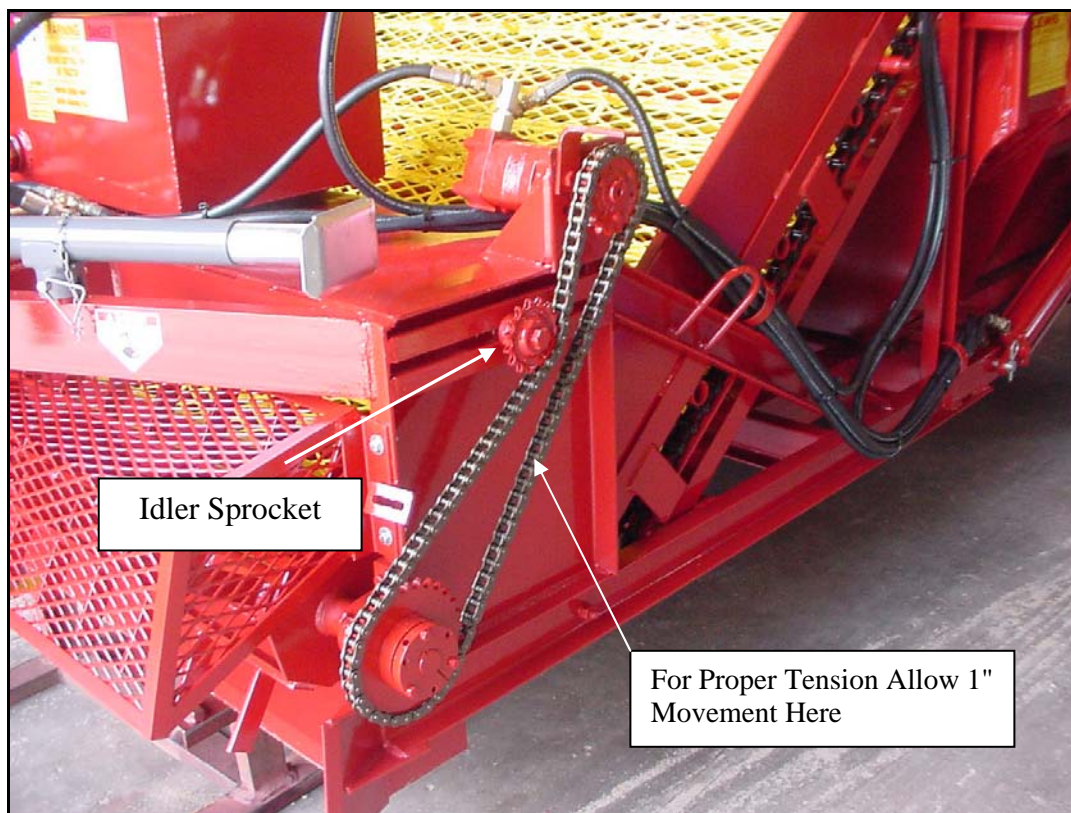

Figure 7

The **loading conveyor chain** will also need adjusting as it wears. To adjust the tension on the chain, loosen all bolts on the base of the upper loading shaft bearing. Next, tighten the adjustment nut on the adjustment rod located at the top of the assembly. Be sure to adjust both sides of the assembly equally before securing the bolts. (See figure 8)

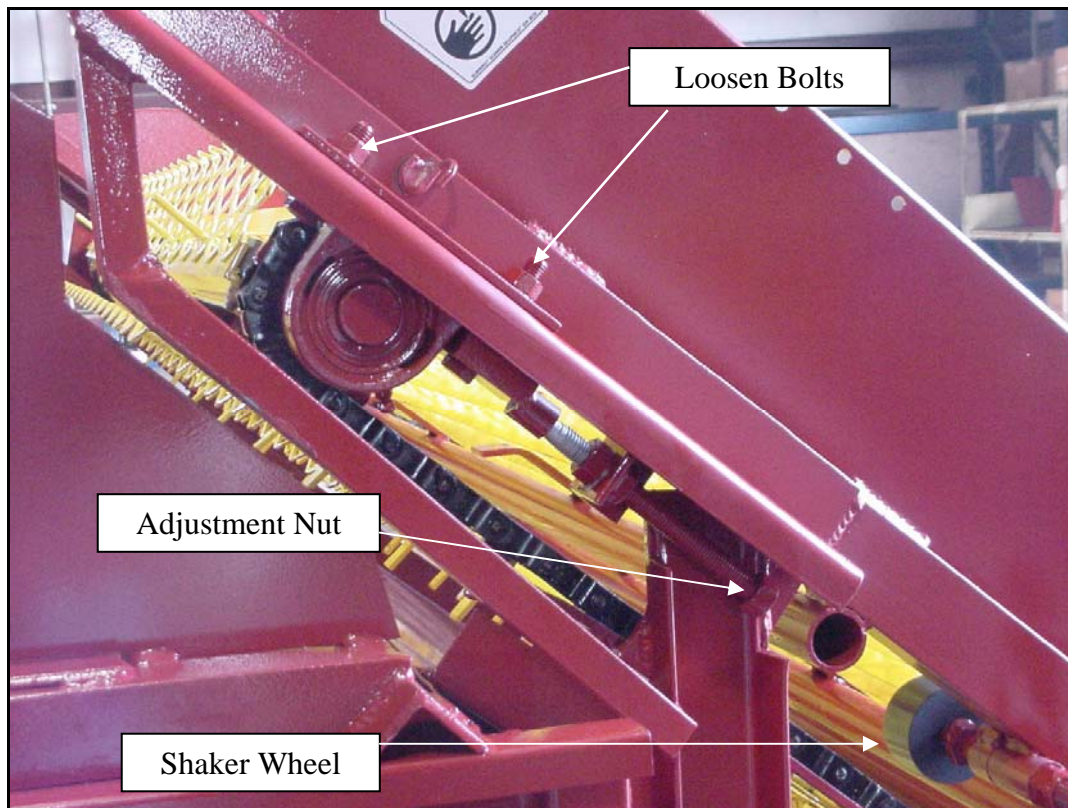

Figure 8

Proper tensioning of this chain should allow you to lift the chain off the side runners between 1-1/2 to 2 inches. (See Figure 8a) When the chain stretches far enough that it cannot be tightened, you must remove two links and one bar and reconnect the chain. Do this by grinding out selected link pins. Reassemble the chain by using an attaching link. Be sure to remove and replace any damaged bars or worn chain links. When adjusting the tension on the leveling chain, there should be contact between the chain and the lower runner with the chain slightly rising off the lower runner at the rear of the machine. (See Figure 8b)

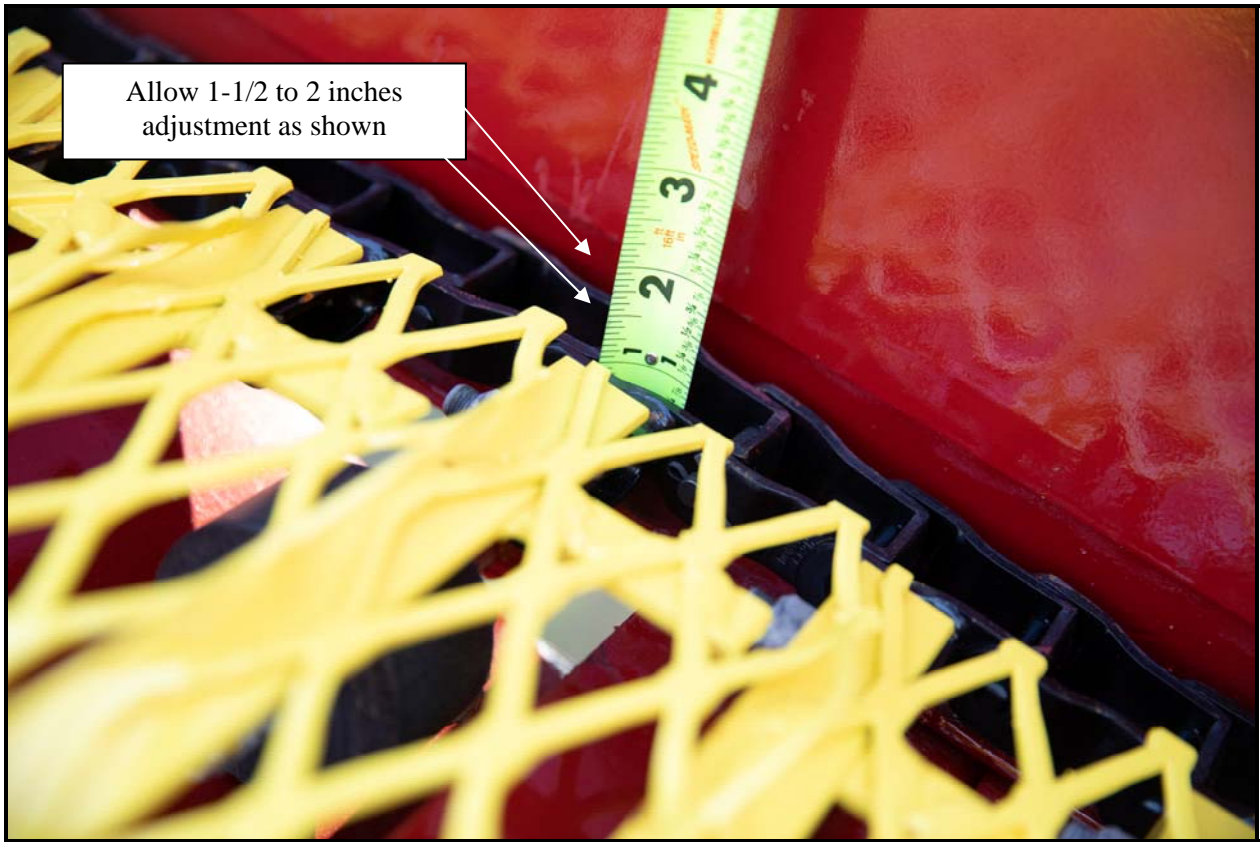

Figure 8a

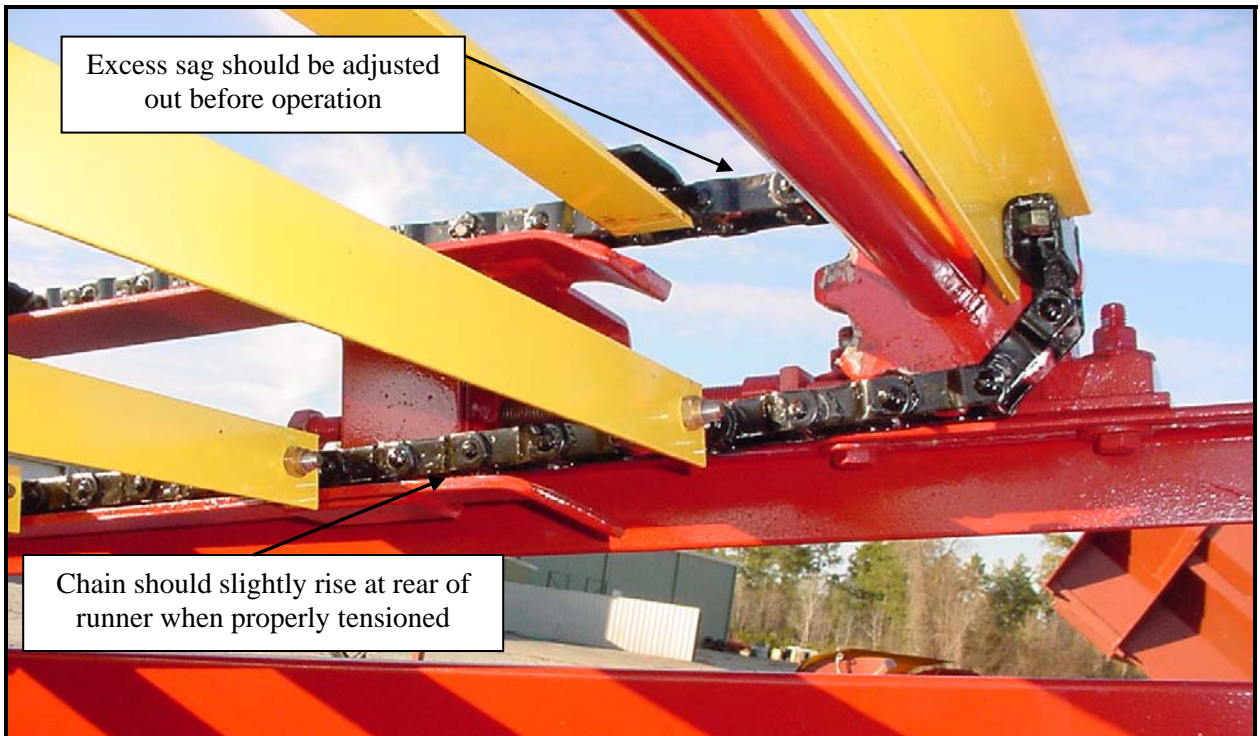

Figure 8b

The **leveling chain assembly** is adjusted from the rear of the assembly. Begin by loosening the jam nut located on the adjustment rod. Next, loosen the bearing flange bolts and turn the adjustment rod to achieve the proper tension. Special care should be taken to adjust both sides of the assembly in equal amounts. Adjusting one side more than the other will cause misalignment of the assembly and damage the assembly. (See Figure 9)

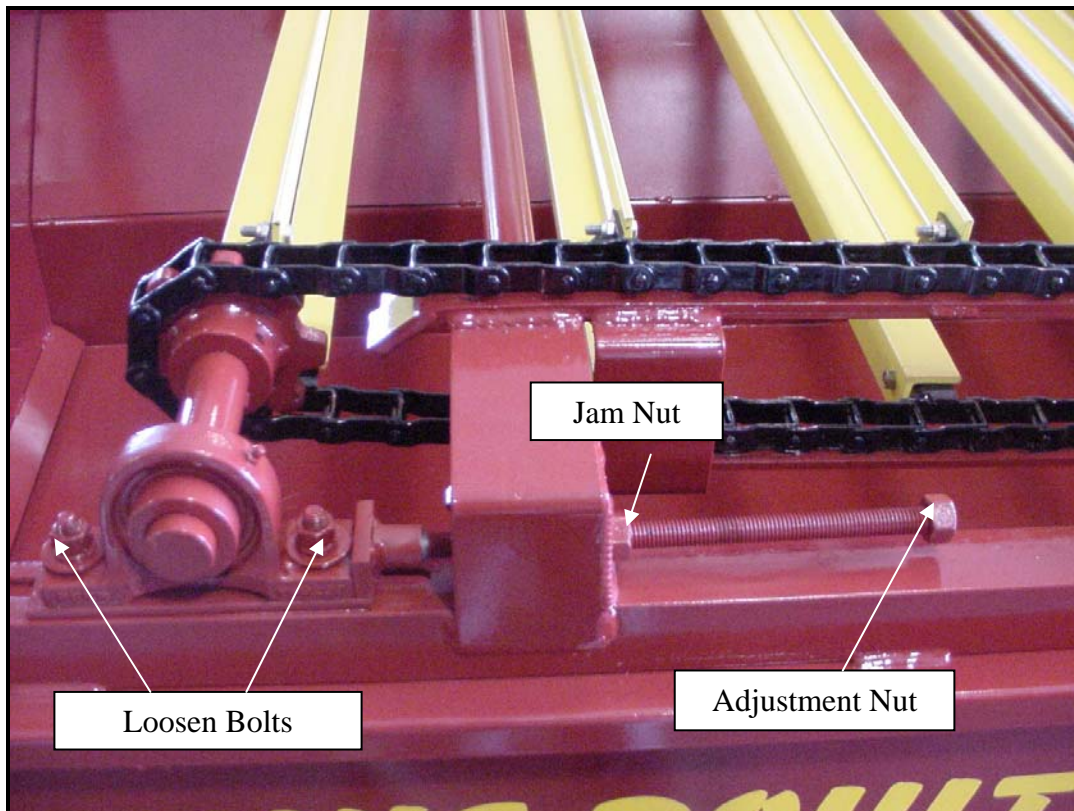

Figure 9

The unloading chain adjustment is located at the front of the chain directly behind the lower portion of the loading conveyor. Adjust both sides of the idler shaft assembly equally by tightening the adjustment nut. (See fig. 10)

The chain should be tightened until approximately 5-3/4" clearance exists between it and the body floor in order to achieve proper tensioning. This should place the bottom of the chain even with, or just below the main frame channel.

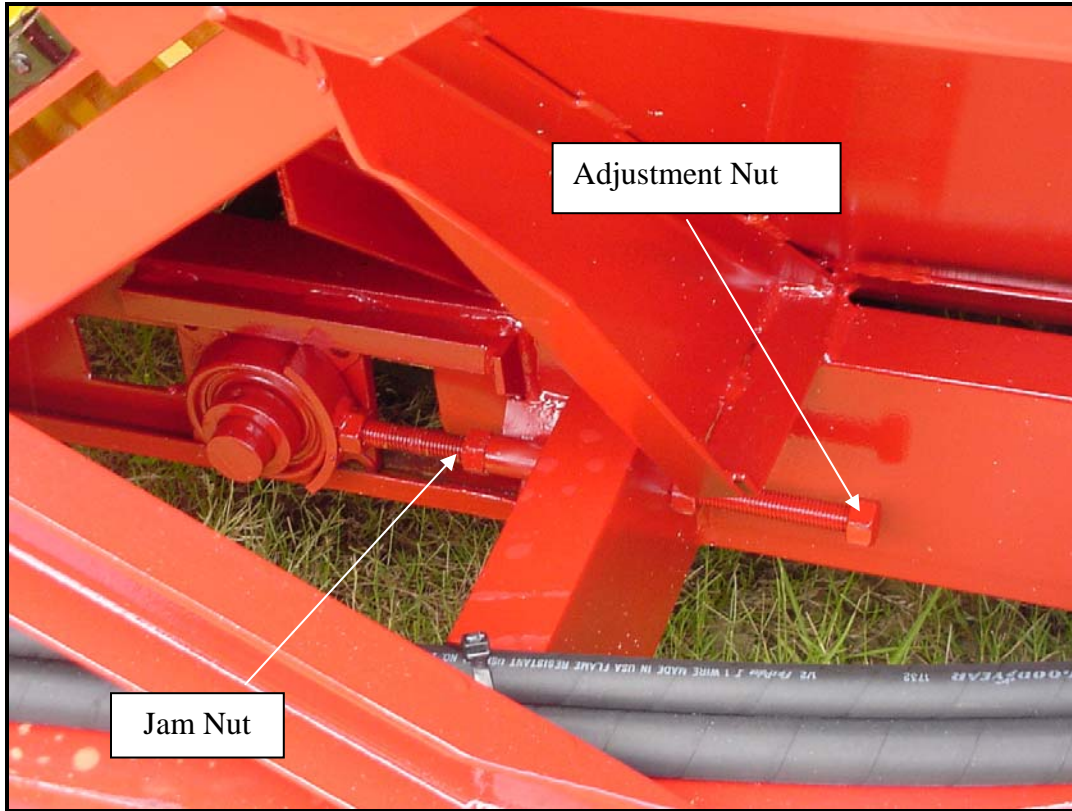

Figure 10

The unloading drive chain can be adjusted by loosening the idler and sliding it downward in the slot. (See Figure 11) Proper adjustment should allow for 1/2" to 1" of movement on the tension side of the chain when not under a load. Once the correct tension has been set, secure the idler by tightening the idler bolt and re-install the guard.

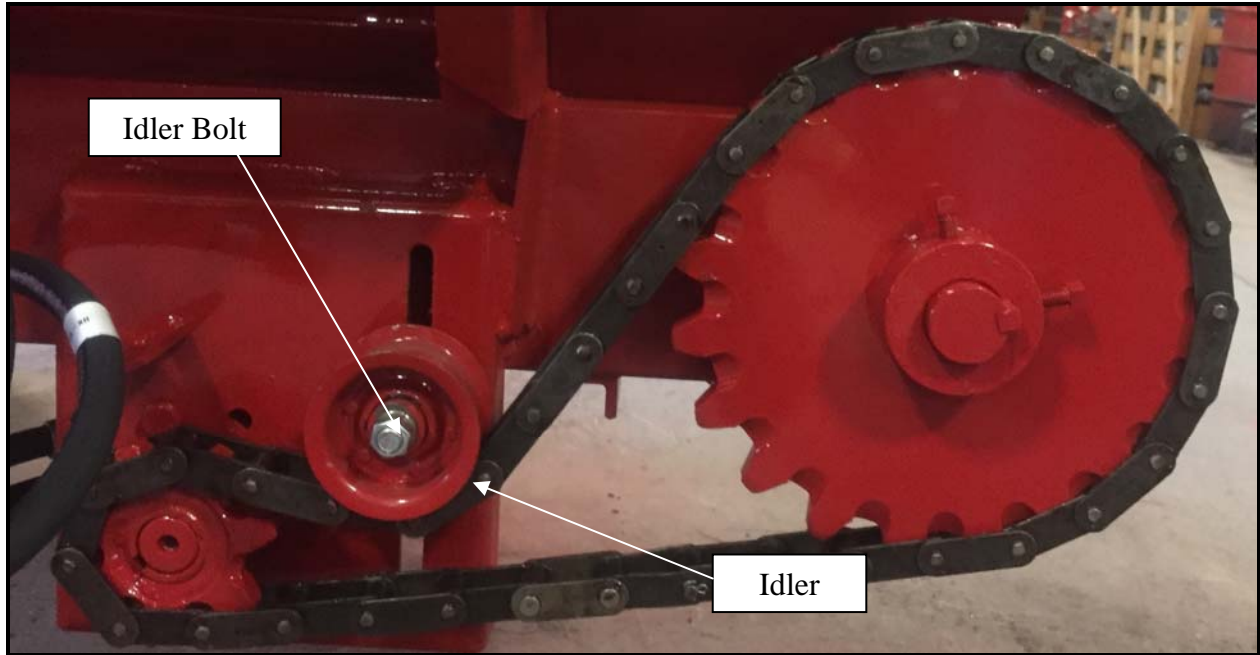

Figure 11

The drive belts on the spreader assembly may need to be adjusted over time. The first step after removing the protective guard is to loosen the idler axle bolt. Tighten the adjustment nut on the draw bolt until the proper tension is achieved. Re-secure the idler assembly by tightening the idler axle bolt. (See Figure 12)

It should take 4-5 pounds of force to deflect a single belt $\frac{5}{16}$ of an inch at the midpoint of the longest span. If no gauge is available to make this measurement, an alternative method of measurement would be to apply moderate force using one finger to push the belt $\frac{5}{16}$ of an inch. Once the proper tension has been achieved for each of the belts, secure their position by tightening the jam nut and axle bolt.

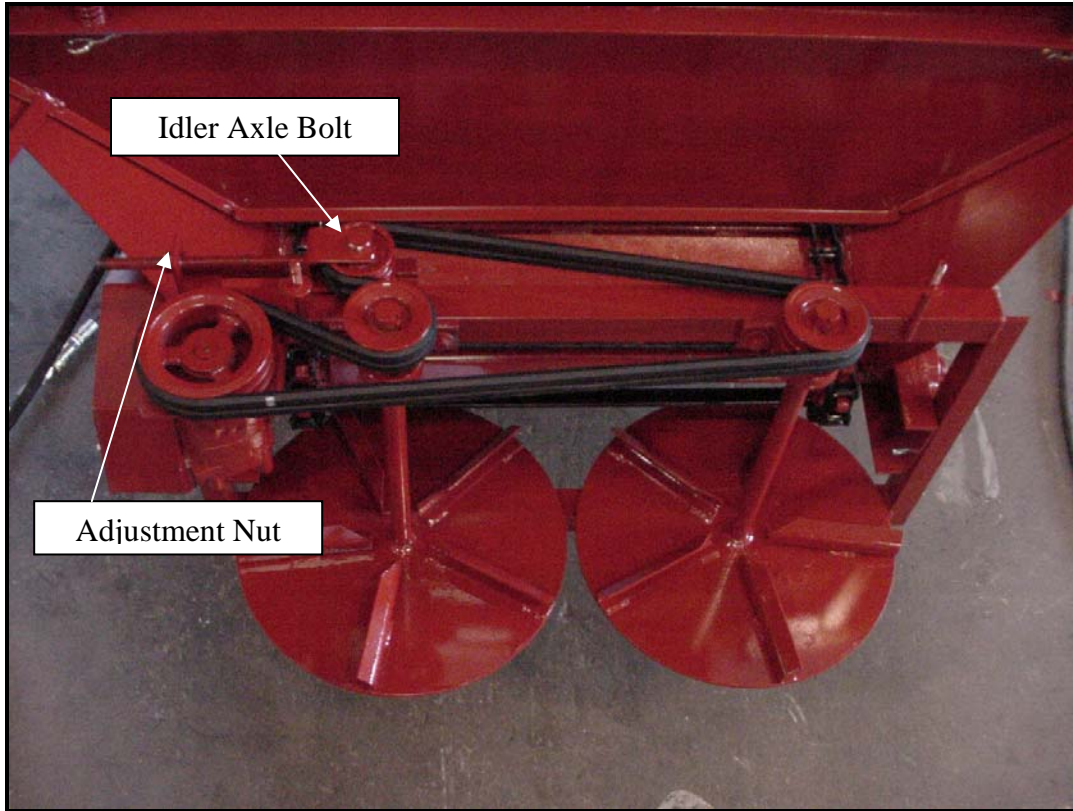

Figure 12

The loading conveyor drive chain should be checked often and any loose slack should be adjusted out before operation. This can be done by first removing the protective guard and loosening the three bolts that secure the hydraulic motor and shaft assembly. (See figure 13) Once the bolts have been loosened, slide the Motor Mount Assembly down-ward to set the proper tension on the Drive Chain, and then lower Chain Idler against the Drive chain. Be careful not to over-tighten the chain as excess tension may cause damage to the loading motor assembly.

After prolonged use, it may be necessary to remove a half link in order to take up slack due to stretching or wear. Follow the same steps as mentioned above once the half link has been removed.

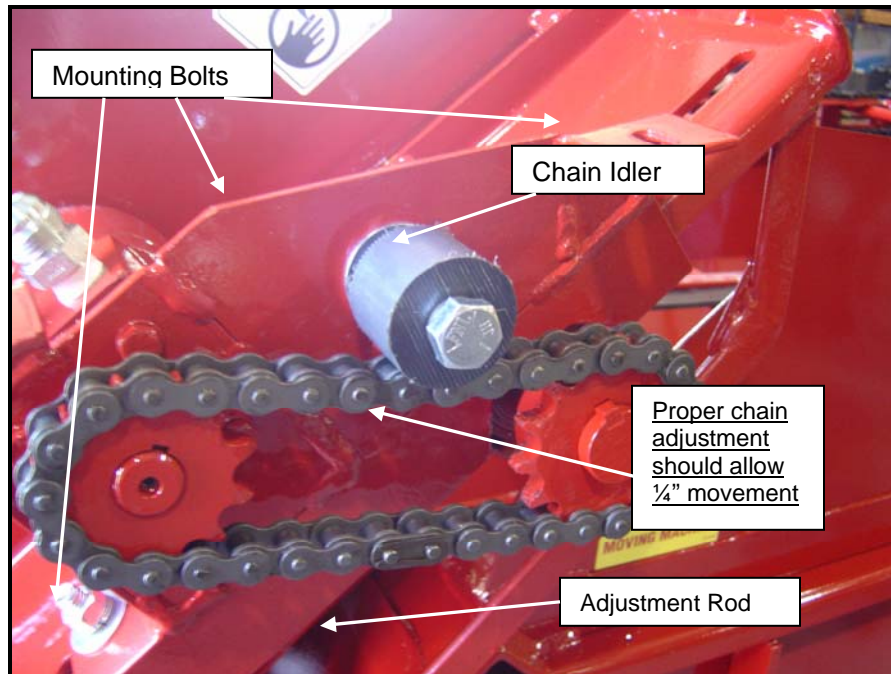

Figure 13

The leveling assembly drive chain should also be checked regularly and adjusted as needed. After removing the guard, locate and loosen the leveling shaft assembly bolts. (See figure 14) Use the adjustment rod to set the proper tension on the drive chain taking care not to over-tighten. Once the proper adjustment has been made re-tighten the assembly bolts and re-install the guard.

ATTENTION: Be sure to keep all drive chains well lubricated and free of obstructions to insure proper operation.

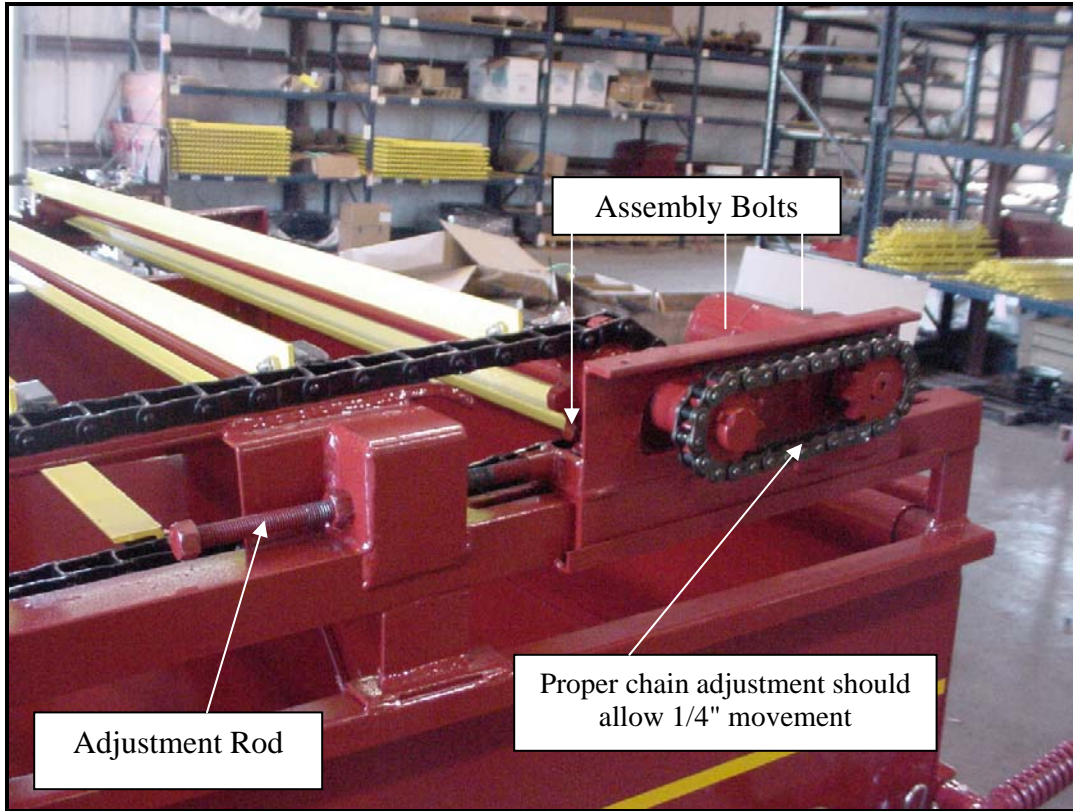

Figure 14

LUBRICATION

HYDRAULIC FLUID

The hydraulic fluid is a vital component of the system. Low levels may cause overheating and damage to hydraulic components. The hydraulic system holds approximately 28 gallons. With the machine on level ground, the oil level in the tank should come to within four inches of the top of the tank. If it becomes necessary to add hydraulic fluid, use petroleum based anti-wear hydraulic oil with ISO 68 viscosity grade AW 68. Oil temperature should not exceed 180 degrees Fahrenheit. In the event that components may need replacing, the hydraulic oil should also be replaced.

CAUTION: Always look for hydraulic leaks with the tractor's engine off. Wear hand and eye protection. Use cardboard or wood instead of your hands to search for a leak source.

Grease the following points lightly each 50 hours and before storage.

1. Spreader Shaft Bearing
2. Rear Unloading Shaft Bearing
3. Tandem Axle Pivots (Under the Axle)
4. Loading Shaft (Top) Bearing
5. Rear Leveling Shaft Bearing
6. Cylinder Reel Bearings
7. Main Loading Motor Support Bearings
8. Pivot Point on Tailgate Spring Unit (Hydraulic dump only)
9. Grease or oil tailgate hinges after each use.
10. Front Unloading Shaft (1 sprocket only)

Grease all chains and bearings after each use. Change the oil filter every six (6) to twelve (12) months depending on usage.

TIRES

Check tire pressure on a regular basis. Adjust the pressure not to exceed 50 PSI.

REPAIRS

Check for worn or damaged components. Order needed parts from your Lewis Dealer. Make all repairs as early as possible to avoid additional expense. Prolonged use of worn or damaged parts may result in premature failure of other components.

DECALS

MODEL #5LP

HK-101435

**SHAKER ROLLERS MUST
BE REMOVED BEFORE
INSTALLING SOLID BARS**

HK-100913

**PAT. #4,897,183
PAT. #6,092,668**

HK-100923

**KEEP AWAY
FROM
MOVING MACHINE**

HK-100986

WARNING



MOVING PART HAZARD
To prevent serious injury or death from moving parts:

- Close and secure guards and shields before starting.
- Keep hand, feet, hair and clothing away from moving parts.
- Disconnect and lockout power source before adjusting or servicing.
- Do not stand or climb on machine when operating.

SUNWEST SCREEN GRAPHICS® SW 404

HK-100908

CAUTION

1. Read Operator's Manual before using machine.
2. Stop tractor engine, lower machine to the ground, place all controls in neutral, set park brake, remove ignition key and wait for all moving parts to stop before servicing, adjusting, repairing, unplugging or fitting.
3. Install and secure all guards before starting.
4. Keep hands, feet, hair and clothing away from moving parts.
5. Do not allow riders.
6. Keep all hydraulic lines, fittings and couplers tight and free of leaks before using.
7. Clean reflectors, SMV and lights before transporting.
8. Install safety locks before transporting or working beneath components.
9. Add extra lights and use pilot vehicle when transporting during times of limited visibility.
10. Use hazard flashers in tractor when transporting.
11. Install safety chain when attaching to tractor.
12. Keep away from overhead electrical lines. Electrocutation can occur without direct contact.
13. Review safety instructions with all operators annually.

SW4

HK-100906

DANGER

KEEP HANDS AND FEET AWAY



SUNWEST SCREEN GRAPHICS® SW 8038

HK-100916

BE CAREFUL

1. KEEP ALL SHIELDS IN PLACE.
2. STOP ENGINE BEFORE LEAVING OPERATOR'S POSITION TO ADJUST, LUBRICATE, CLEAN OR UNCLOG MACHINES.
3. WAIT FOR ALL MOVEMENT TO STOP BEFORE SERVICING THE MACHINE.
4. KEEP HANDS, FEET AND CLOTHING AWAY FROM POWER DRIVEN PARTS.
5. KEEP OFF EQUIPMENT UNLESS SEAT OR PLATFORM FOR OPERATION AND OBSERVATION IS PROVIDED.
6. KEEP ALL OTHERS OFF.
7. USE FLASHING WARNING LIGHTS WHEN OPERATING ON HIGHWAYS EXCEPT WHEN PROHIBITED BY LAW.
8. MAKE CERTAIN EVERYONE IS CLEAR OF MACHINE BEFORE STARTING ENGINE OR OPERATION.

HK-100899

HK-100899



HK-100918



HK-100917



HK-100910

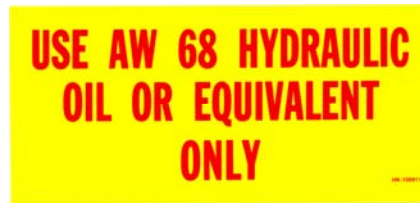

HK-100911



HK-100907



HK-100912



HK-100919

PARTS

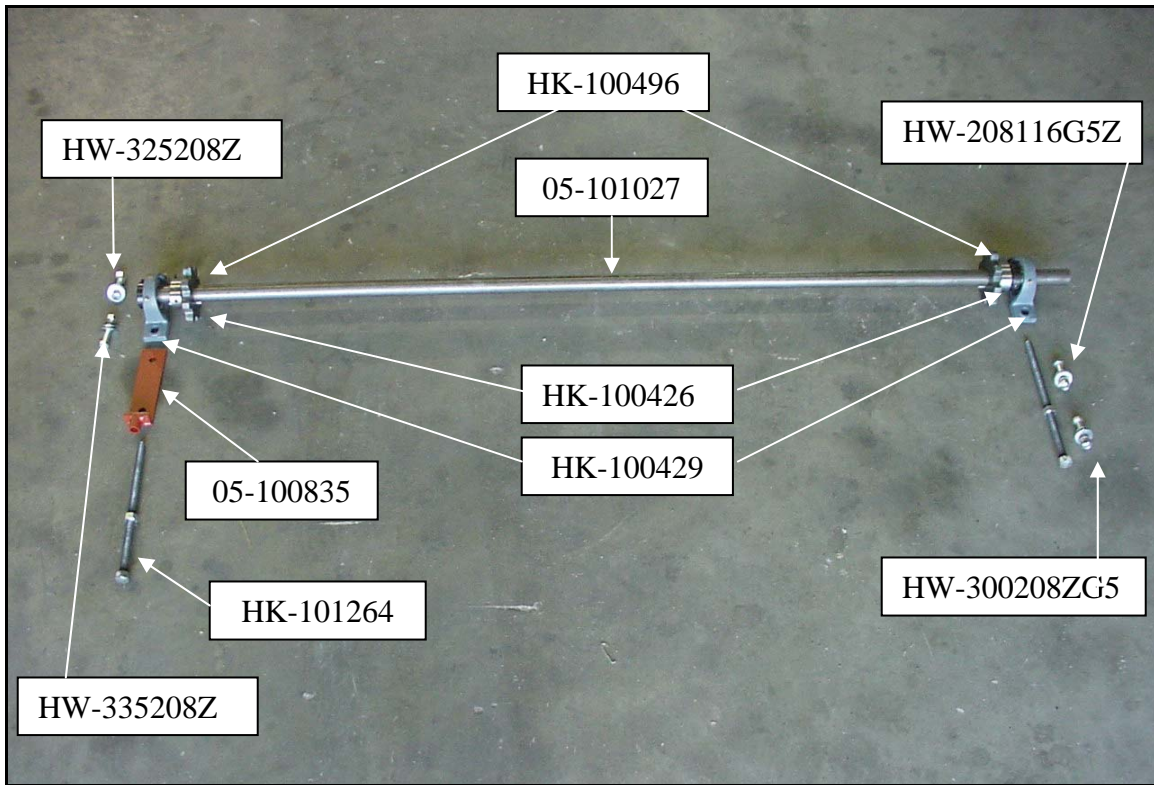

Leveling Shaft Assembly (HK-100477)

05-101027	Shaft
HK-100426	Sprocket
HK-100429	Bearing
HK-100496	Key 5/16 Square X 2-1/2''
05-100835	Adjustment Rod Assembly
HK-101264	Tensioning Rod Assembly
HW-208116G5Z	Bolt
HW-325208Z	Flat Washer
HW-335208Z	Lock Washer
HW-300208ZG5	Nut

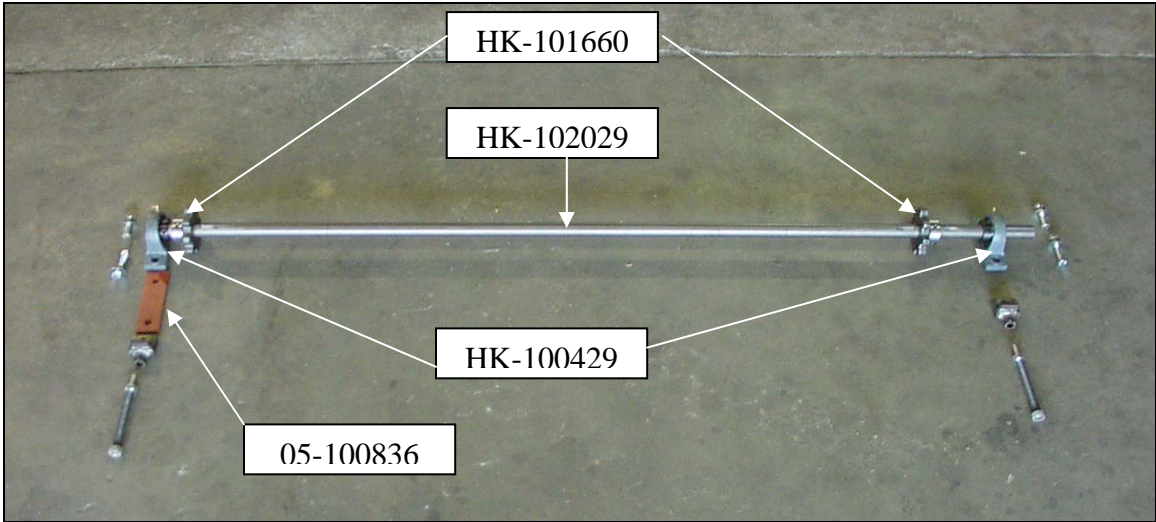

Upper Loading Conveyor Shaft Assembly (05-100830)

HK-1022029	Shaft, Top Loading
HK-101660	Sprocket, Top Loading w/ Angular Ring (after serial # 5468)
HK-100429	Bearing
HK-100496	Key, 5/16 Square X 2-1/2"
05-100836	Slide, Leveling Conveyor

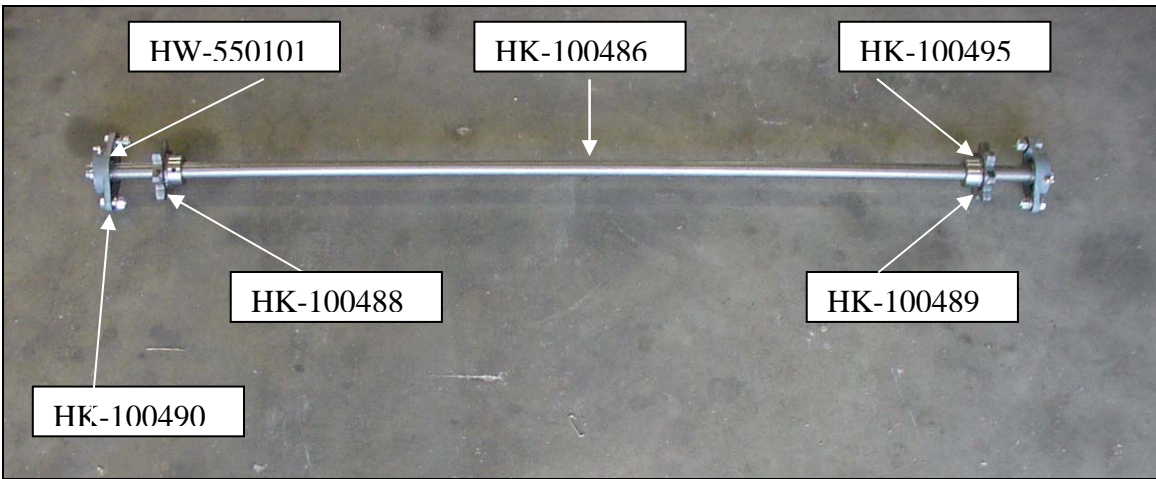

Lower Loading Conveyor Shaft Assembly (05-101025)

HK-100486	Shaft, Lower Loading (after serial # 5468)
HK-100488	Sprocket, Lower Loading with Bushing
HK-100489	Sprocket with Keyway
HK-100490	Bearing
HK-100495	Key, Cylinder Reel, 1/4 Square
HW-550101	1/8 NPT Straight Grease Fitting

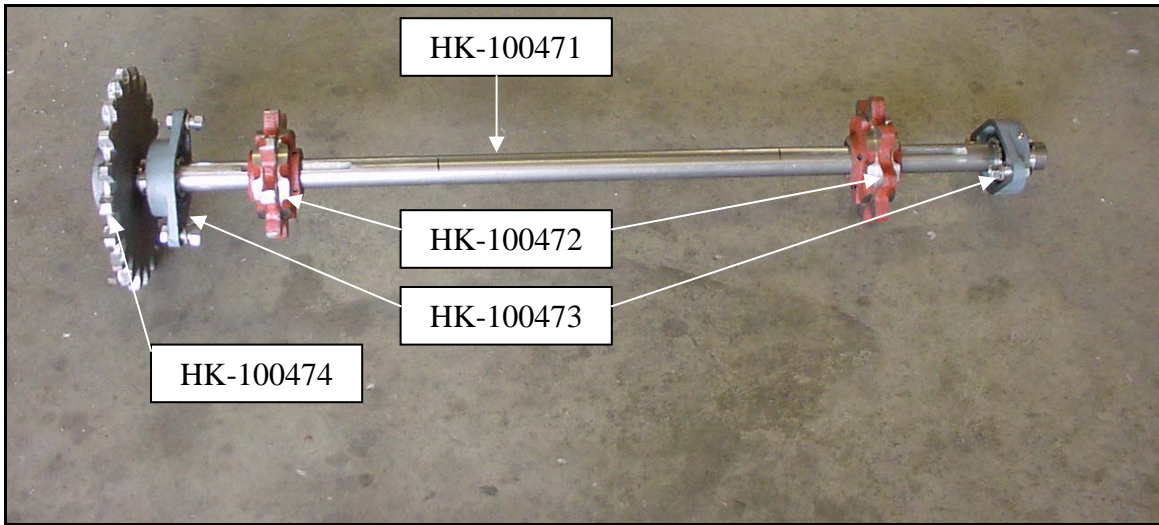

Rear Unloading Shaft Assembly (HK-100470)

HK-100471	Shaft, Rear Unloading
HK-100472	Sprocket
HK-100473	Bearing
HK-100474	Sprocket

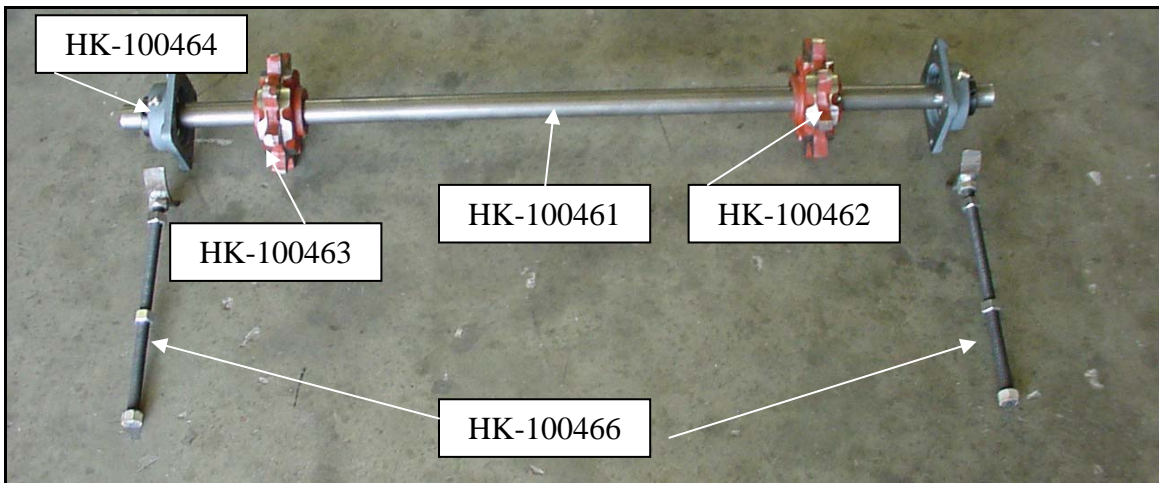

Front Unloading Shaft Assembly (HK-100460)

HK-100461	Shaft, Front Unloading
HK-100462	Sprocket With Grease Fitting
HK-100463	Sprocket With Set Screw
HK-100464	Bearing, Flange
HK-100466	Tensioning Rod Assembly

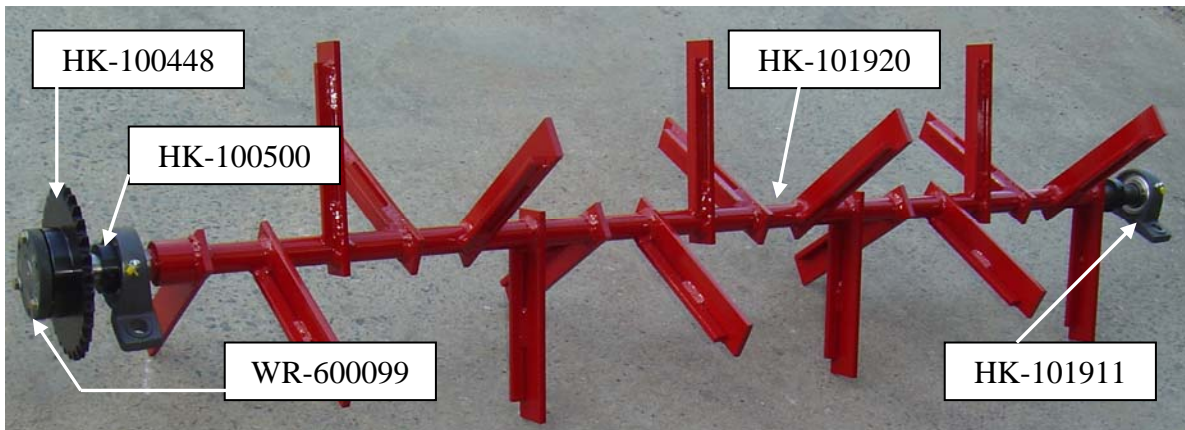

Cylinder Reel Assembly (HK-101910)

HK-101911	Bearing
HK-100448	Sprocket
WR-600099	Bushing
HK-100500	Key 3/8 Square X 2-1/2"
HK-101920	Cylinder

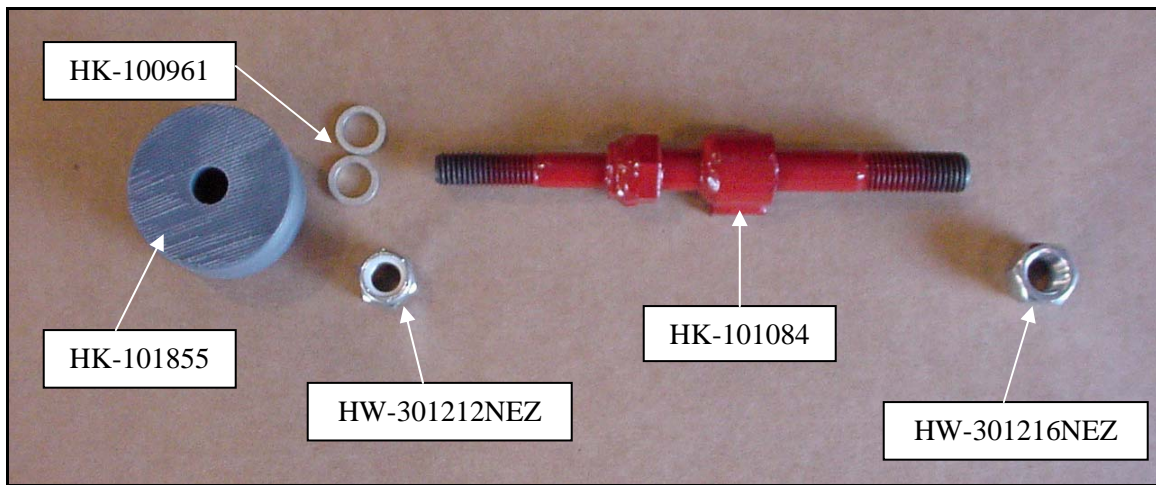

Shaker Wheel Assembly (HK-101549)

HK-100961	Shim-Space
HW-301212NEZ	Locknut, Hex 5/8-11NC, ZP Nylon
HW-301216NEZ	Locknut, Hex 3/4-10NC, ZP
HK-101855	Black Shaker Wheel, Nylon
HK-101084	Shaft, Shaker Wheel

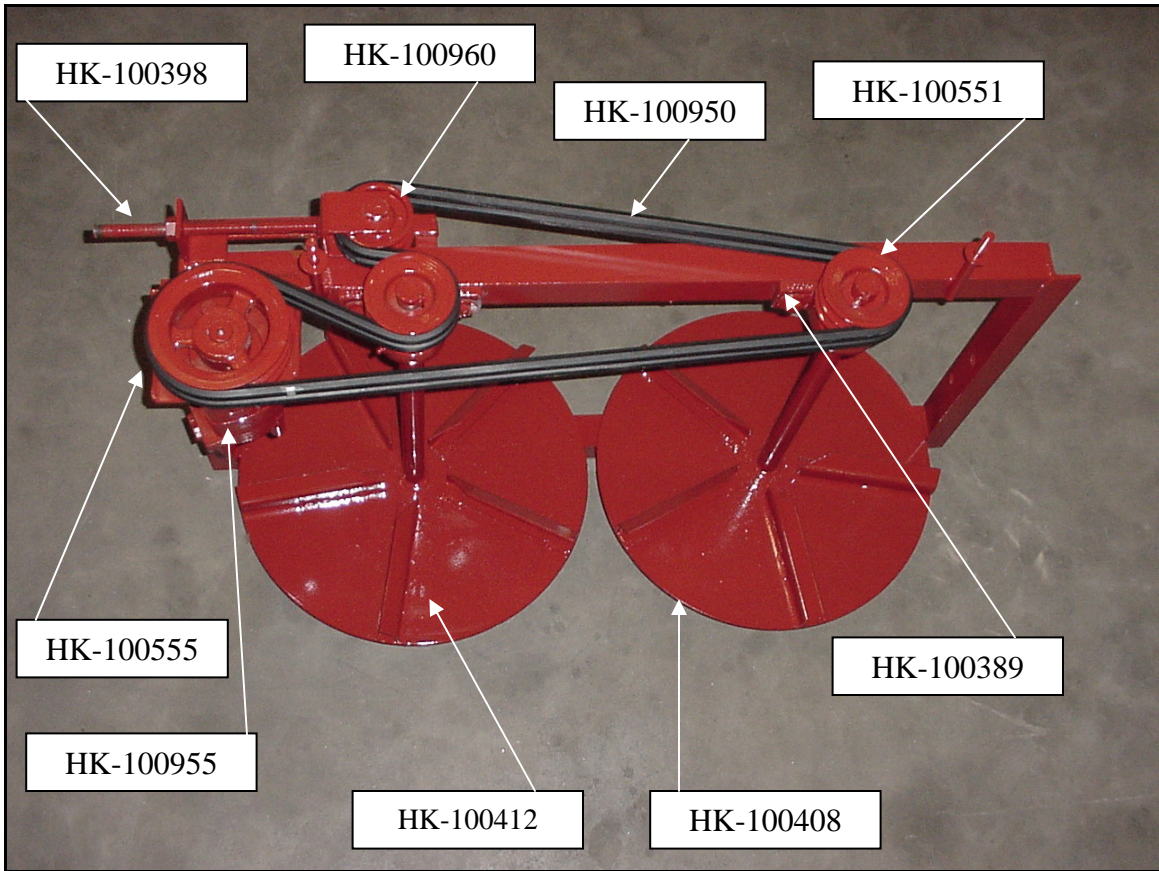

Spinner Option

HK-100408	Shaft with Blade Weldment, RH
HK-100412	Shaft with Blade Weldment , LH
HK-100389	Bearing
HK-100551	Pulley
HK-100960	Pulley, Spreader Idler
HK-100398	Belt Adjustment Rod
HK-100555	Pulley, Leveling
HK-100955	Spinner Motor
HK-100950	Belt

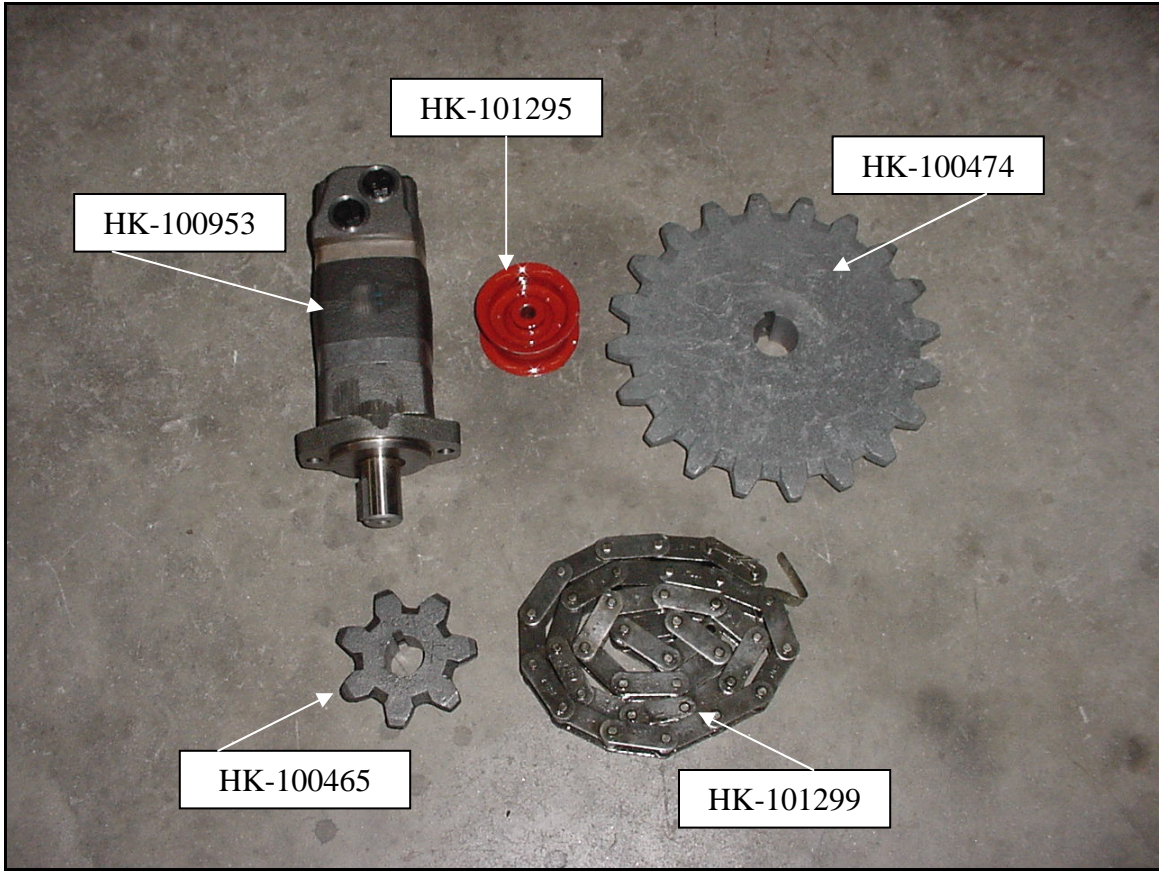

Unloading Motor & Parts

HK-100953	Unloading Motor
HK-101295	Idler
HK-100474	Sprocket
HK-101299	Drive Chain
HK-100465	Sprocket, Unloading Drive
HK-101297	Connecting Link (not shown)
HK-101658	Offset Link (not shown)

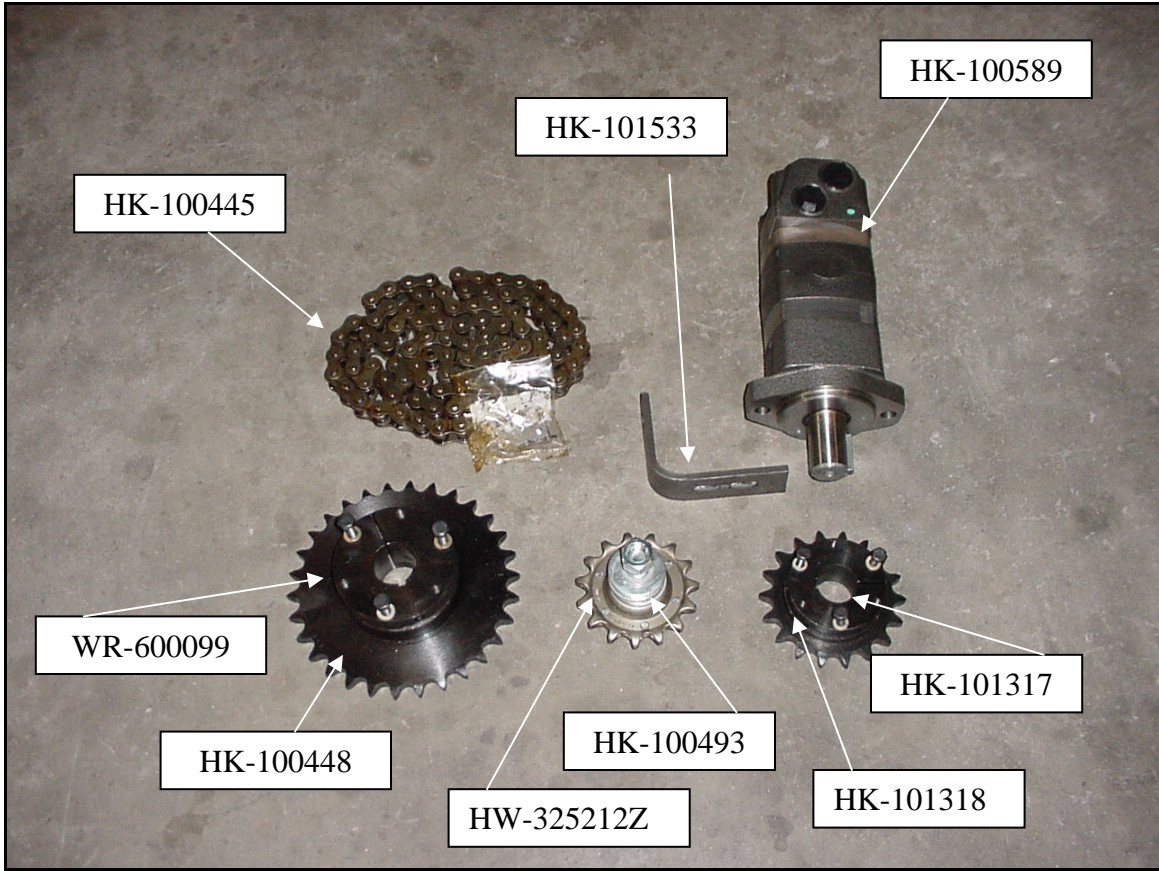

Cylinder Motor & Parts

HK-100445	Chain, #60 Roller, 95 Pitches	
HK-101533	Guard Mount	
HK-100589	Cylinder Motor	
HK-101317	Sprocket, 60 SDS 18H	
HK-101318	Taper Bushing	
HK-100493	Idler	
HW-325212Z	5/8USS,Flat Washer, ZP	
HK-100448	Sprocket	
WR-600099	Bushing	
HK-101270	Connecting Link	(not shown)
HK-101320	Offset Link	(not shown)

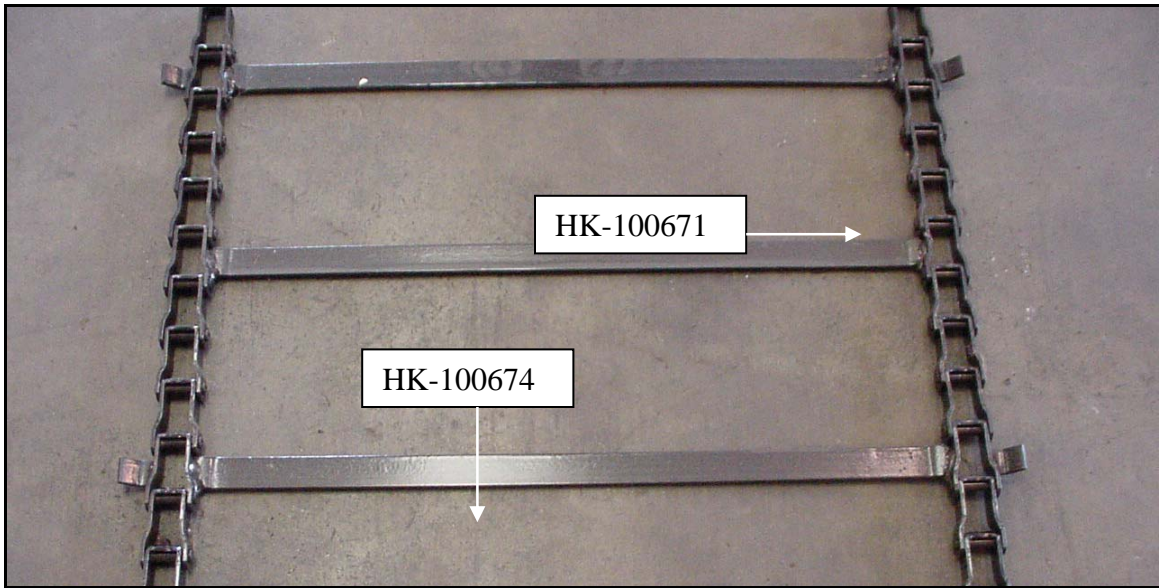

Unloading Chain (HK-101296)

HK-100671	Chain Link
HK-100674	Unloading Bar Assy

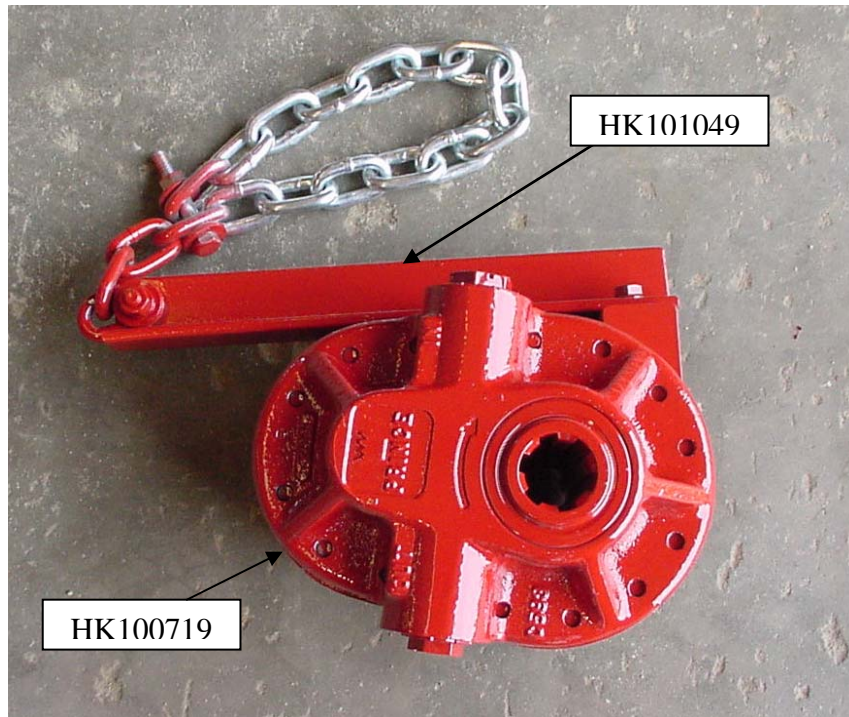

PTO Pump Kit (HK-101330)

Part Number	Description	Quantity
HK-101049	Torque Arm Weldment	1
HK-100719	Pump	1



#	PART #	DESCRIPTION	#	PART #	DESCRIPTION
1	HK-101762	90° HYD. ELBOW	2	HK-101578	90° HYD. ELBOW
3	HK-101760	45° HYD. ELBOW	4	HK-101713	HYD. ADAPTER
5	HK-101759	HYD. ADAPTER	6	HK-101574	HYD. ADAPTER
7	HK-100972	90° HYD. ADAPTER	8	HK-101642	90° HYD. ELBOW
9	HK-101633	90° HYD. ELBOW	10	HK-100974	PORT ADAPTER
11	HK-101763	SWIVEL ADAPTER	12	HK-100978	HYD. ADAPTER
13	HK-101761	90° HYD. ELBOW	14	HK-100970	90° HYD. ELBOW
15	HK-101582	90° HYD. ELBOW	16	HK-101572	HYD. ADAPTER
17	HK-101721	SWIVEL ADAPTER	18	HK-101754	REDUCER
19	HK-101755	REDUCER	20	HK-101718	90° HYD. ELBOW
21	HK-101757	45° HYD. ELBOW	22	HK-101764	90° HYD. ADAPTER
23	HK-100966	QUICK COUPLER KIT	24	HK-100776	1-1/4 NIPPLE
25	HK-100963	1/2 NIPPLE	26	HK-101439	BUSHING
27	HK-101756	TEE	28	HK-101765	3/4 HYD. TEE
29	HK-101758	90° HYD. ELBOW	30	HK-101634	3/4 HYD. TEE
31	HK-100976	1/2 HYD. TEE	32	HK-101711	1/2 HYD. TEE
33	HK-100994	CAP, QUICK CONNECT	34	HK-100993	PLUG, QUICK CONNECT

HYDRAULIC HOSES

1	HK-101750	12EX-12FJ-276" LG	Control Valve to Variable Speed Valve
2	HK-101749	12EX-12FJ-12MJ-192" LG	Rear variable speed return to hyd. tank
3	HK-101565	12EX-12FJ90°-12MJ-145" LG	Loading motor to Leveling Motor (Front Section)
4	HK-101564	12EX-12FJ90°-105" LG	Cyl. Motor to loading Motor
5	HK-100980	20PE-20MP-108" LG	Tank to Pump (Suction Hose)
6	HK-101570	12EX-12FJ-96" LG	Control Valve to Tank
7	HK-101748	12EX-12FJ-92" LG	Control Valve to Cyl.Motor
8	HK-101751	12EX-12FJ-12MOBX-72" LG	Pump to Control Valve
9	HK-101753	EX08-08MPX-08MP-96" LG	Quick Couple to Tongue Cylinder
10	HK-101568	6AXT-6FJ-218" LG	POC Valve to Cyl. Motor
11	HK-101752	EX06-06FJ-132" LG	Pump case Drain to Oil Tank
12	HK-101745	8AXT-8MPX-8FJ-94" LG	Leveling motor to Return
13	HK-101741	8AXT-8MP-8FJ-47" LG	Spinner Motor to rear Variable Speed valve Return
14	HK-101742	8AXT-8FJ-8MP-45" LG	Rear Variable speed to Spinner motor
15	HK-101744	8AXT-12FJ-8MPX-42" LG	Loading Motor to Leveling Motor(Rear section)
16	HK-101743	8AXT-8FJ-8FJ-23" LG	Rear Variable Speed Valve to Unloading Motor
17	HK-101747	8AXT-8FJ-8MPX-23" LG	Tailgate to Check Valve
18	HK-101746	8AXT-8FJ-20" LG	Unloading Motor to Rear variable Speed Valve Return
19	HK-101740	4AXT-6FJ-4MPX-50" LG	Variable speed Valve (pressure in) to POC (Cyl.)

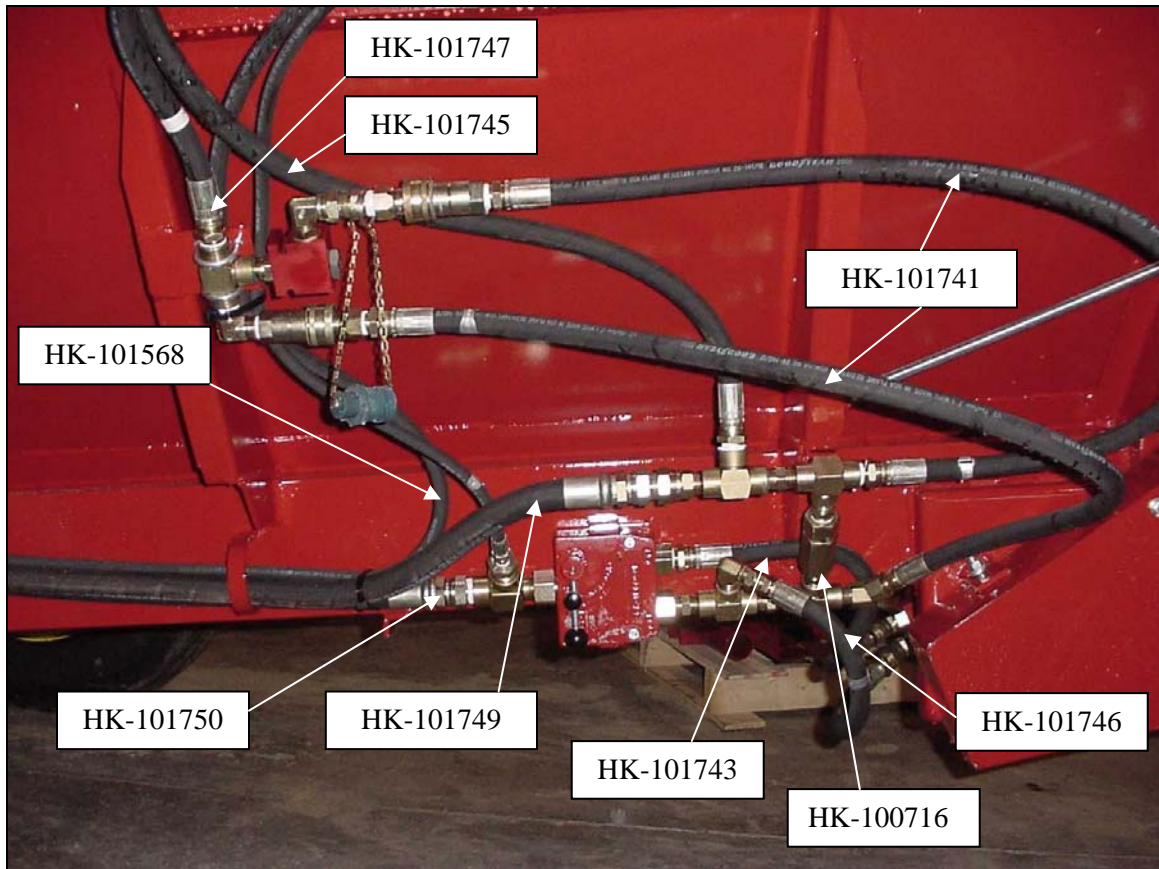

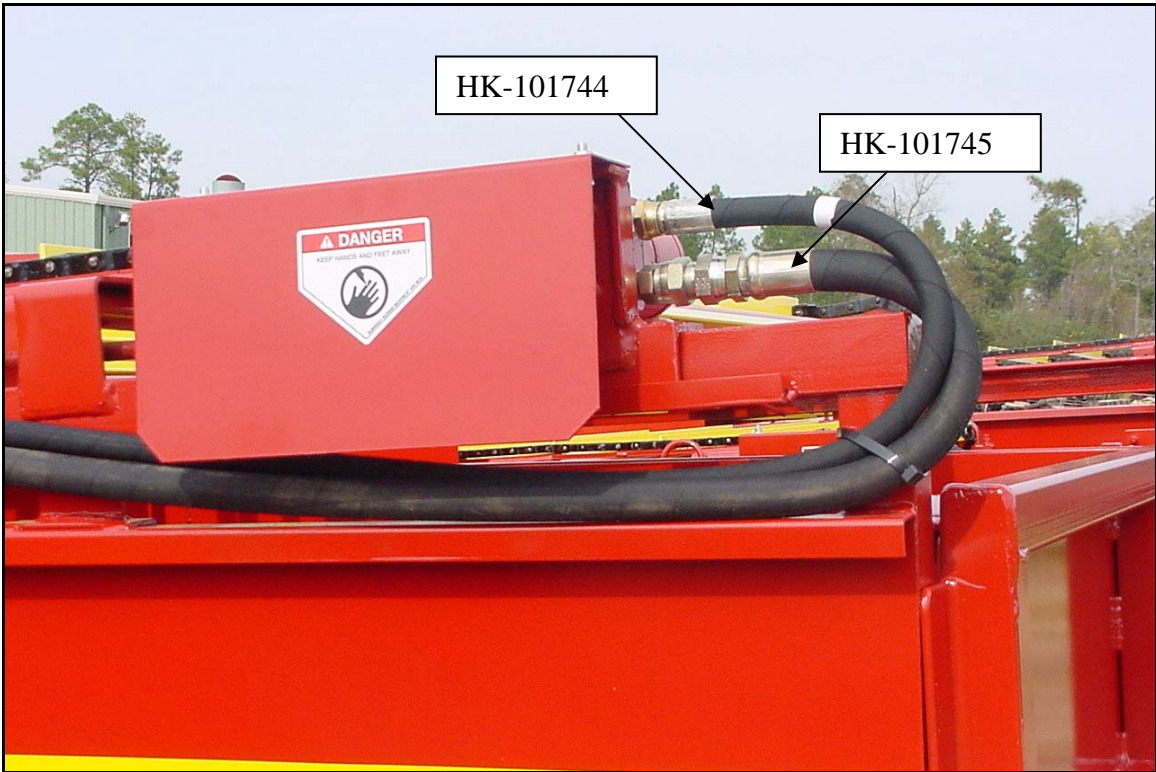

Leveling Motor Assembly



Loading Motor Assembly

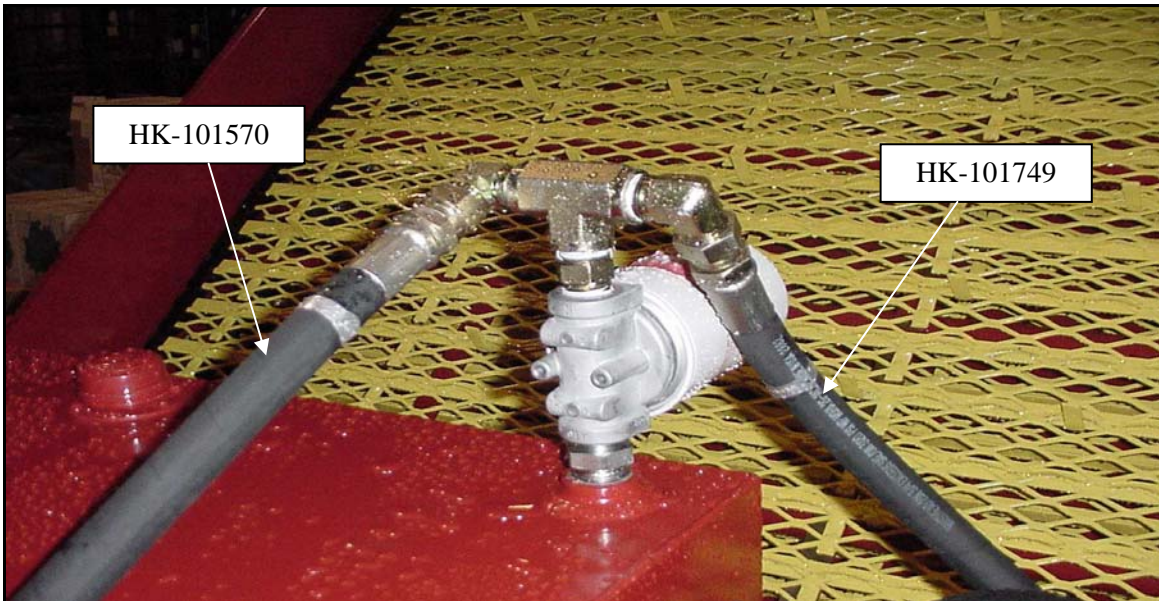
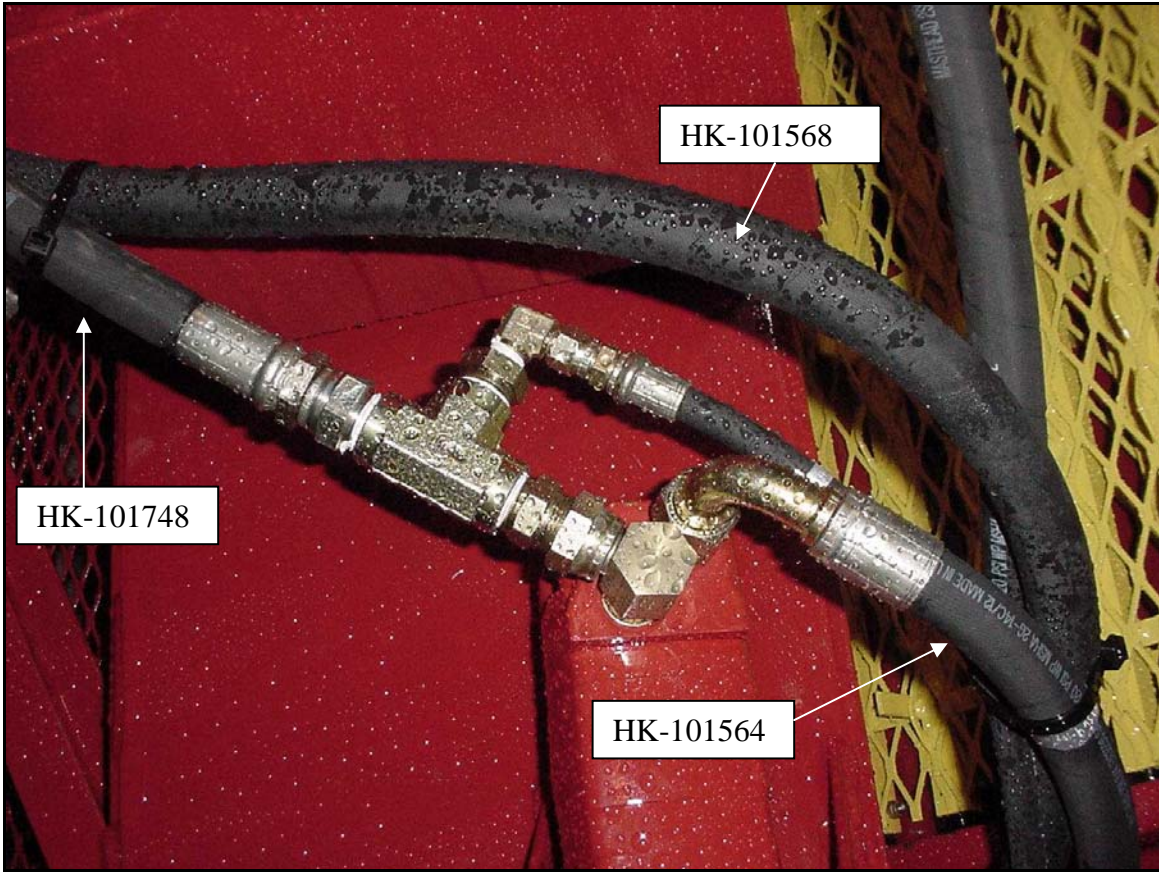

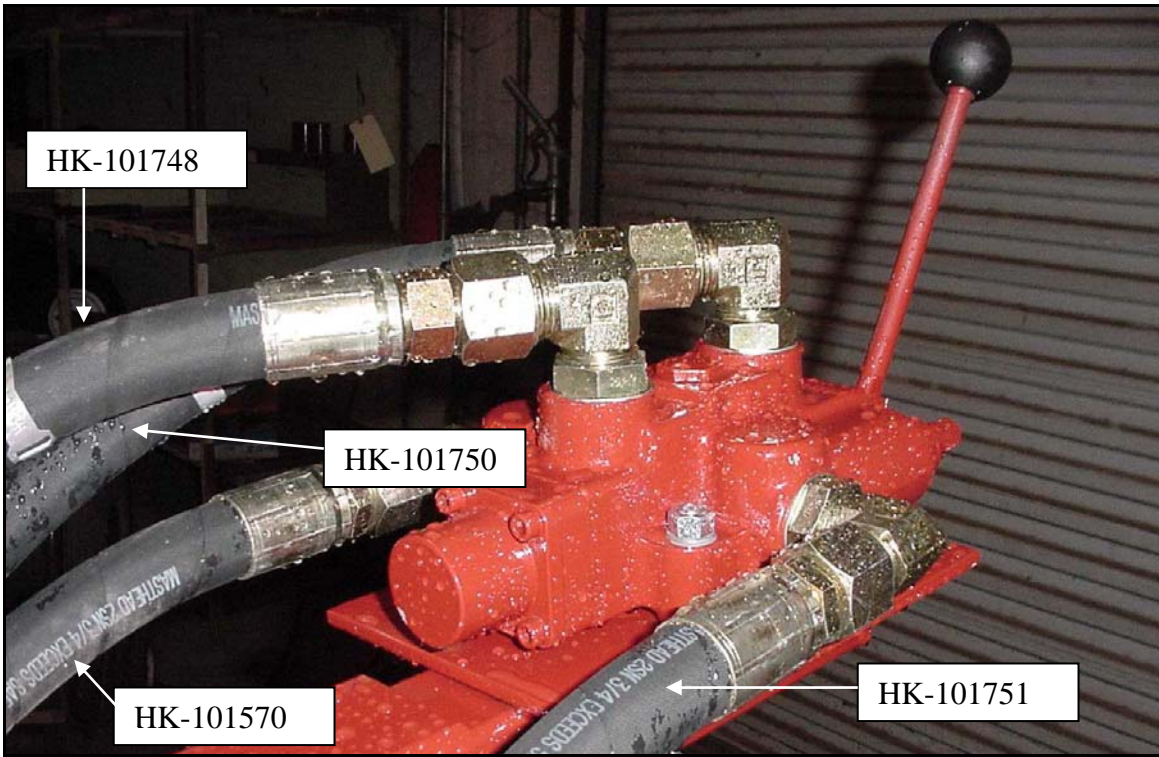

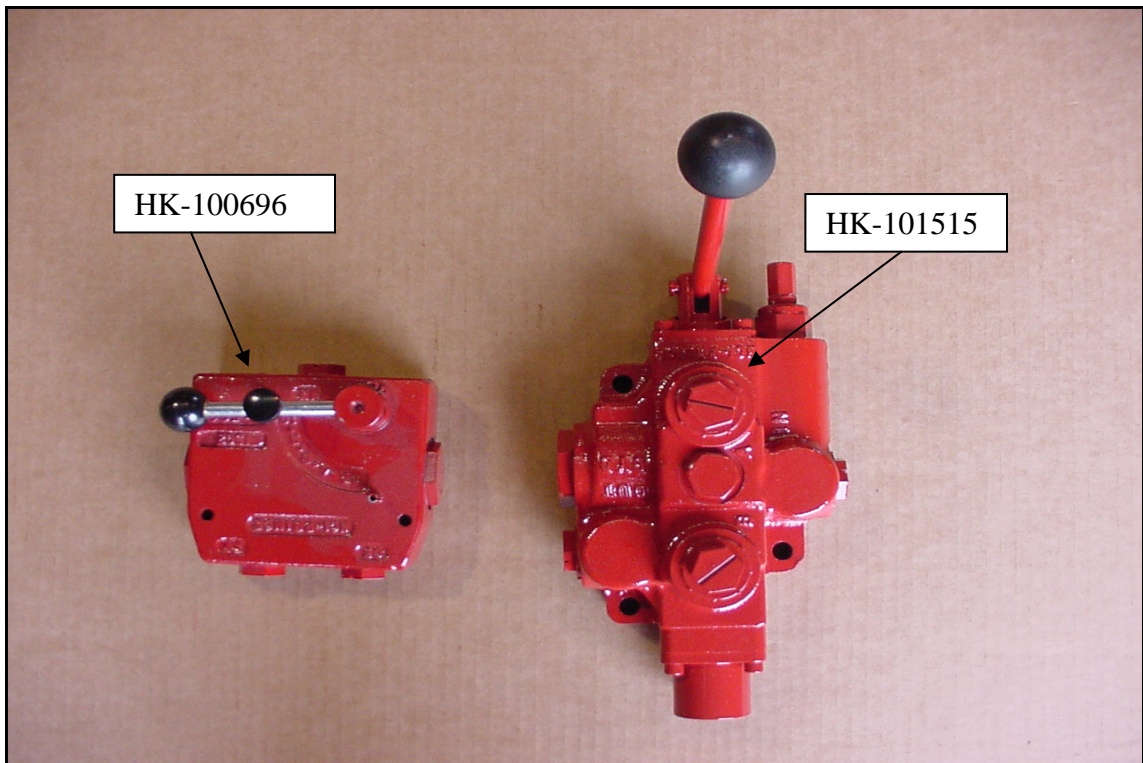
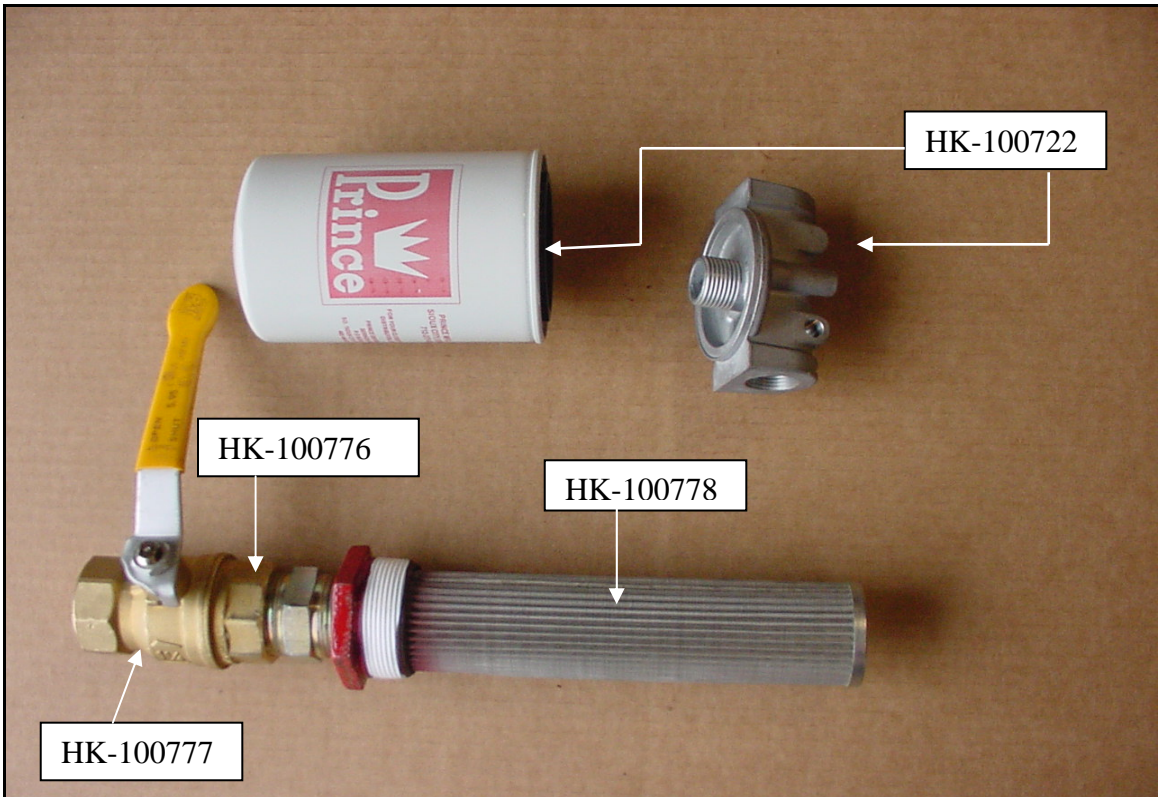

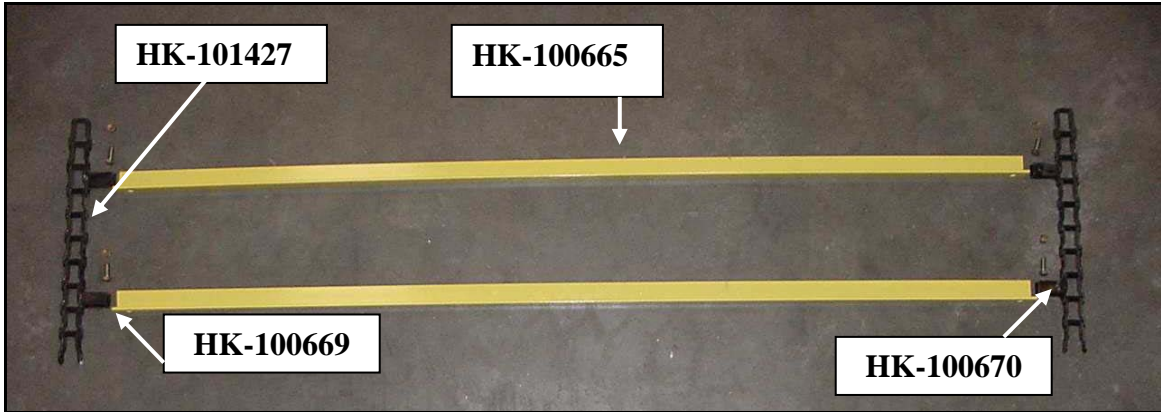

Leveling Chain Assembly (HK-101428)

Part Number	Description	Quantity
HK-101427	Leveling Chain	1
HK-100665	Bar	23
HK-101096	Nut	46
HK-101097	Bolt	48
HK-100669	Bar Attaching Link	Repair Item
HK-100670	Bar Attaching Link	Repair Item

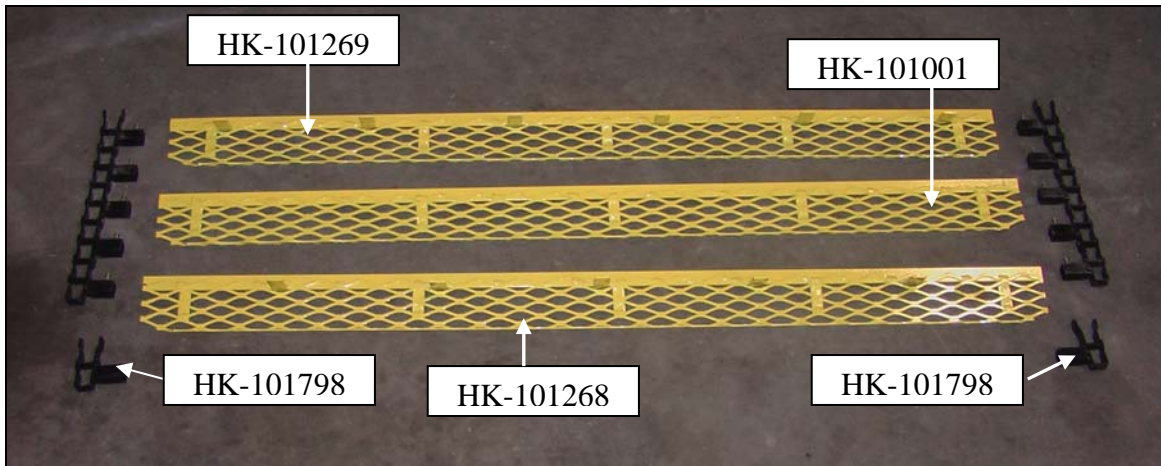

Loading Chain (HK-101802) & Bar Kit (HK-101274)

Part Number	Description	Quantity
HK-101802	Loading Chain with Bolts (serial # 6586)	1
HK-101274	Shaker Bar Kit Complete	1
HK-101001	1-1/2" Mesh Shaker Bar (No Peg)	22
HK-101268	1-1/2" Mesh Shaker Bar (5 Peg)	8
HK-101269	1-1/2" Mesh Shaker Bar (6 Peg)	7
HK-101004	1" Mesh Angle Bar (5 Peg)	7
HK-101798	Bar Attaching Link RH & LH	Repair Item

Full Load Indicator Kit

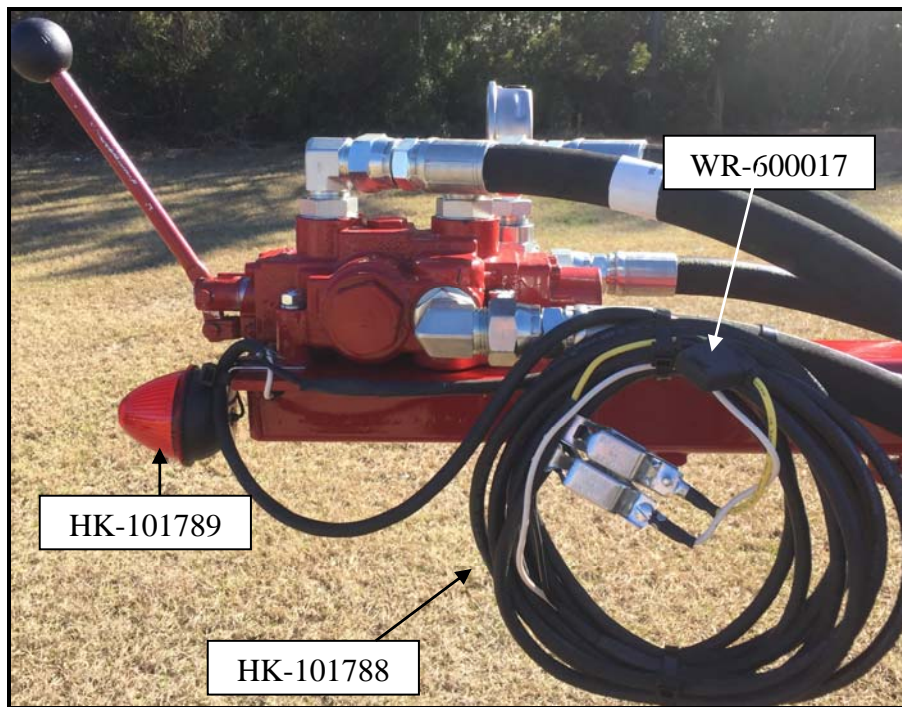
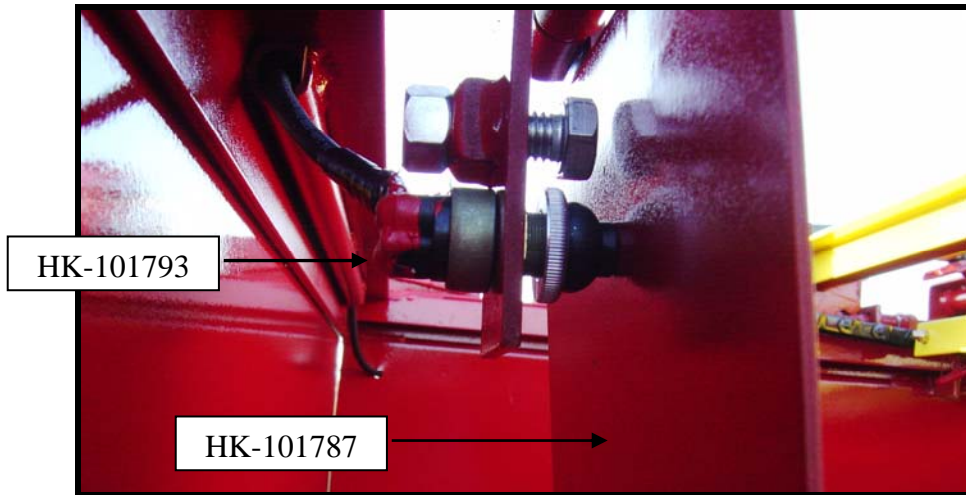

Part Number	Description
HK-101794	Full Load Indicator Kit
HK-101791	Insulated Ring Terminals
HK-101788	Electrical Cable 16/2 sjow Type
HK-101793	Momentary Push Button Switch
Hk-101789	Light
HK-101792	Non Strip Splicer
WR-600017	Fuse Holder
HW-208108SS	Bolt, HH, 1/2-13NC x 1-1/2" LG 18-8 Stainless Steel
HW-300208ZG5	Nut, Hex, 1/2-13NC Zinc Plated, Gr5
HK-101872	Alligator Clip
HK-101787	Switch Activator Weldment

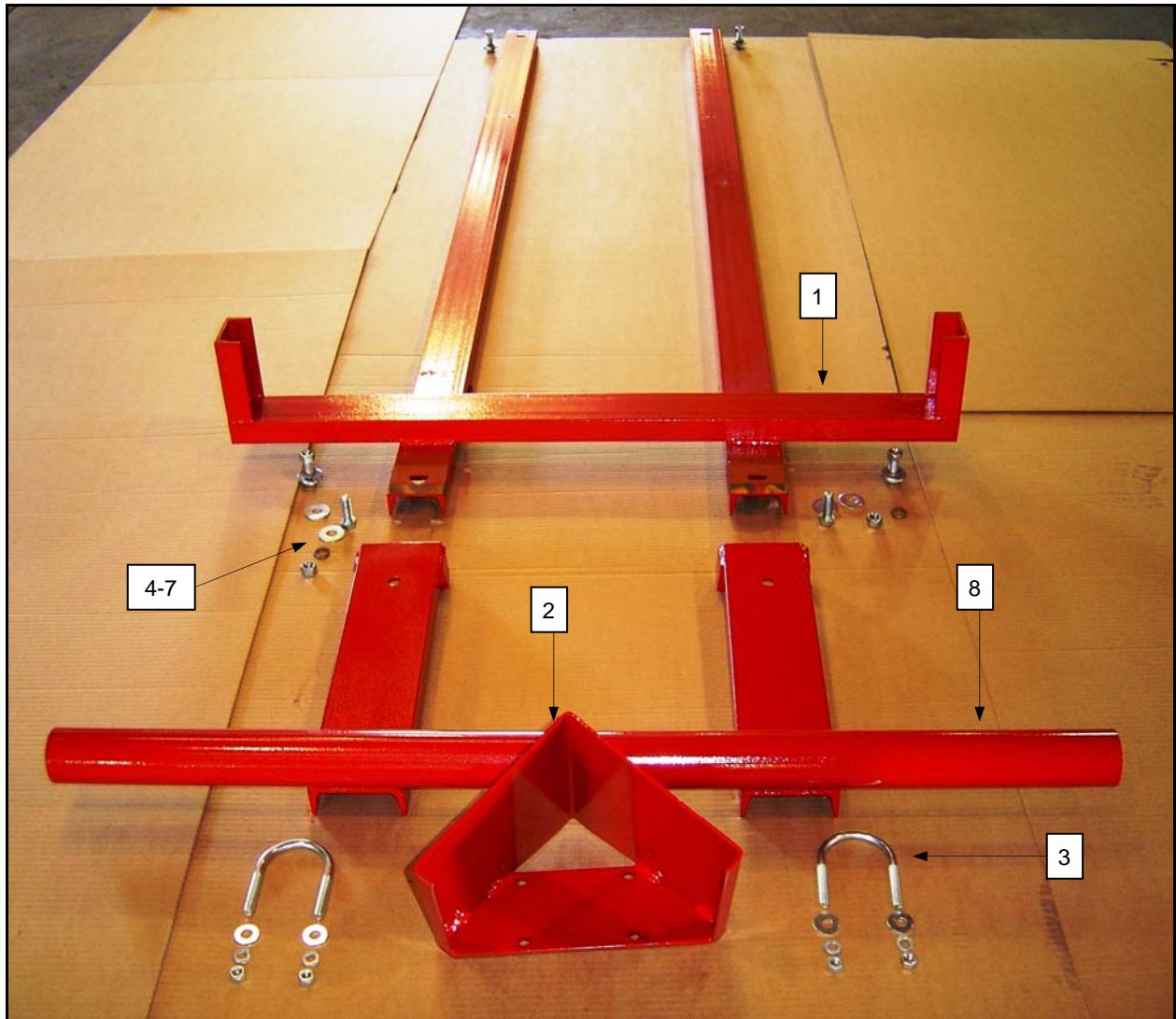

Spinner Bumper Assembly

Ref.	Part #	Description
1	HK-101816	Bumper, Front
2	HK-100015	Flow Divider Weldment
3	SP-200115	U-Bolt
4	HW-208108G5Z	Bolt, HH, Sp, 1/2"-13nc x 1-1/2", Gr5
5	HW-325208Z	Washer, Flat, 1/2" ZP USS Std
6	HW-335208Z	Washer, Lock, 1/2" ZP
7	HW-300208ZG5	Nut, Hex, 1/2"-13nc , ZP
8	HK-101818	Bumper, Rear

Optional

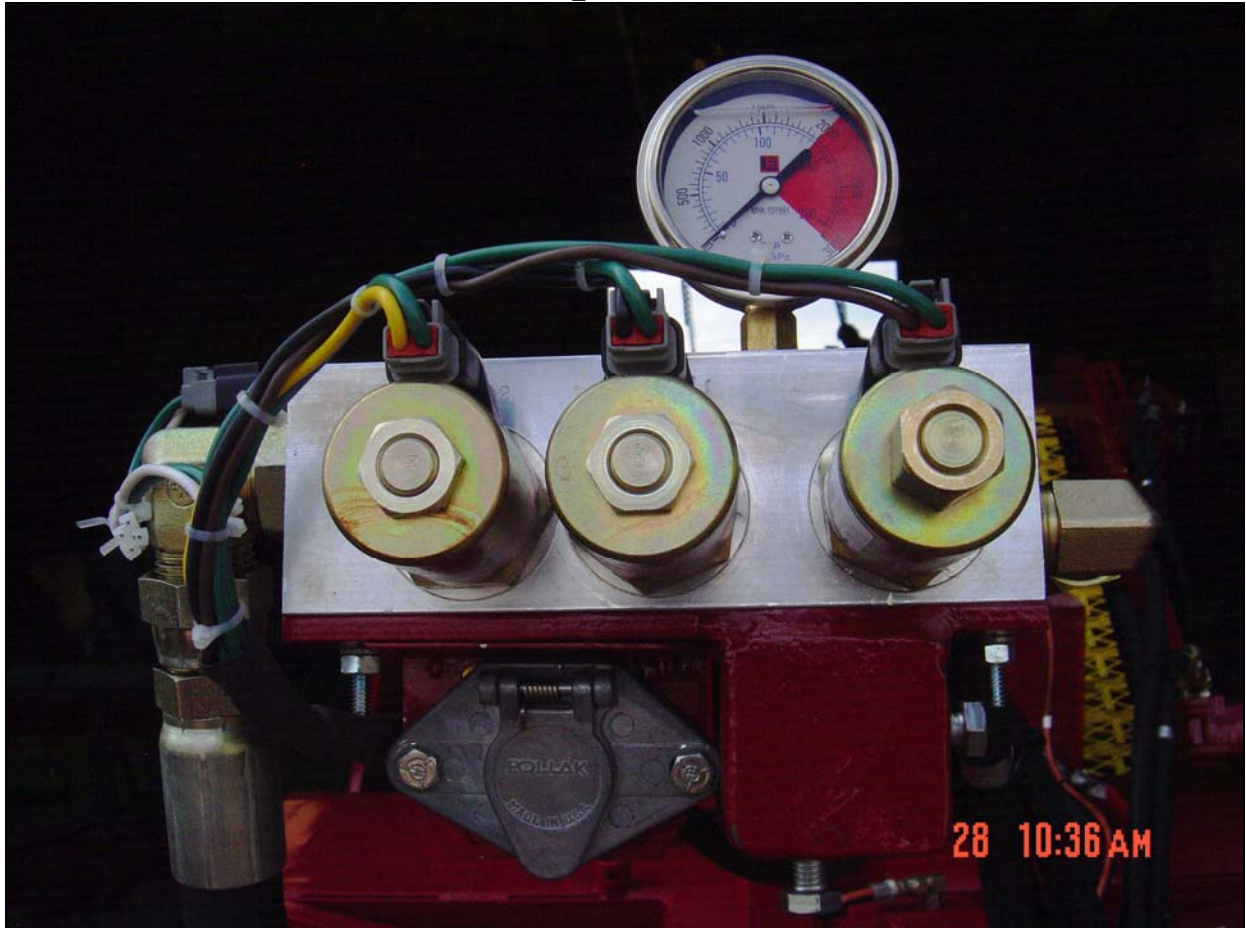

Electric Control Valve Kit

HK-101738

ELECTRICAL SCHEMATIC

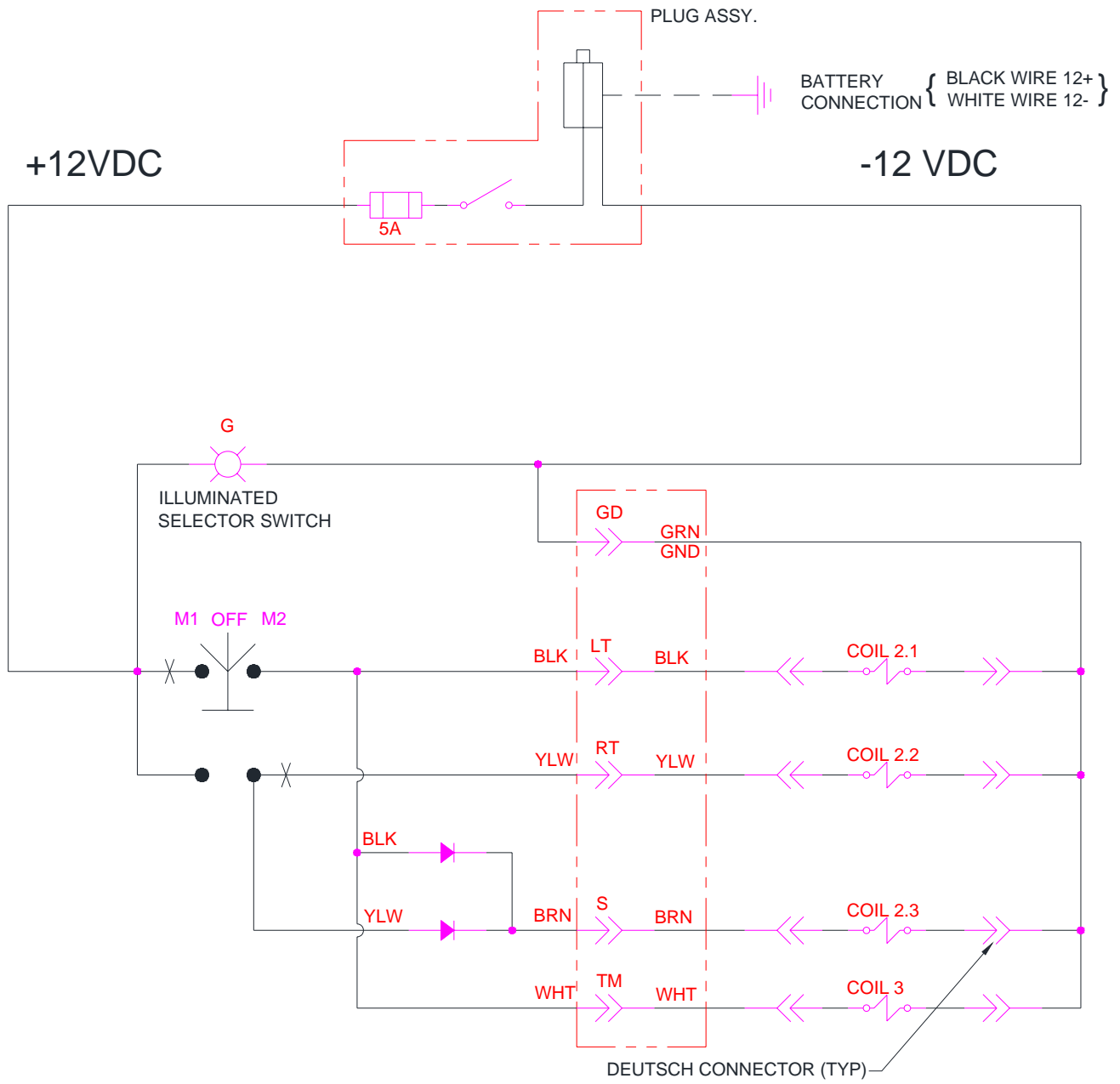

DWG NO. HK-101731	
REV.	DESCRIPTION
DATE	APVD

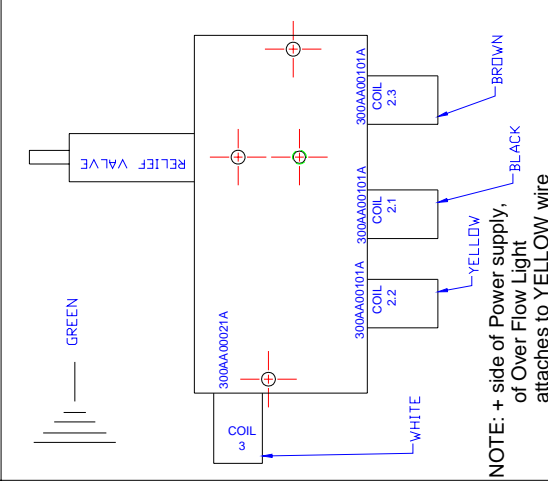
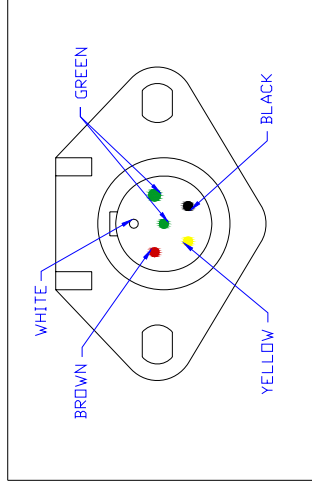
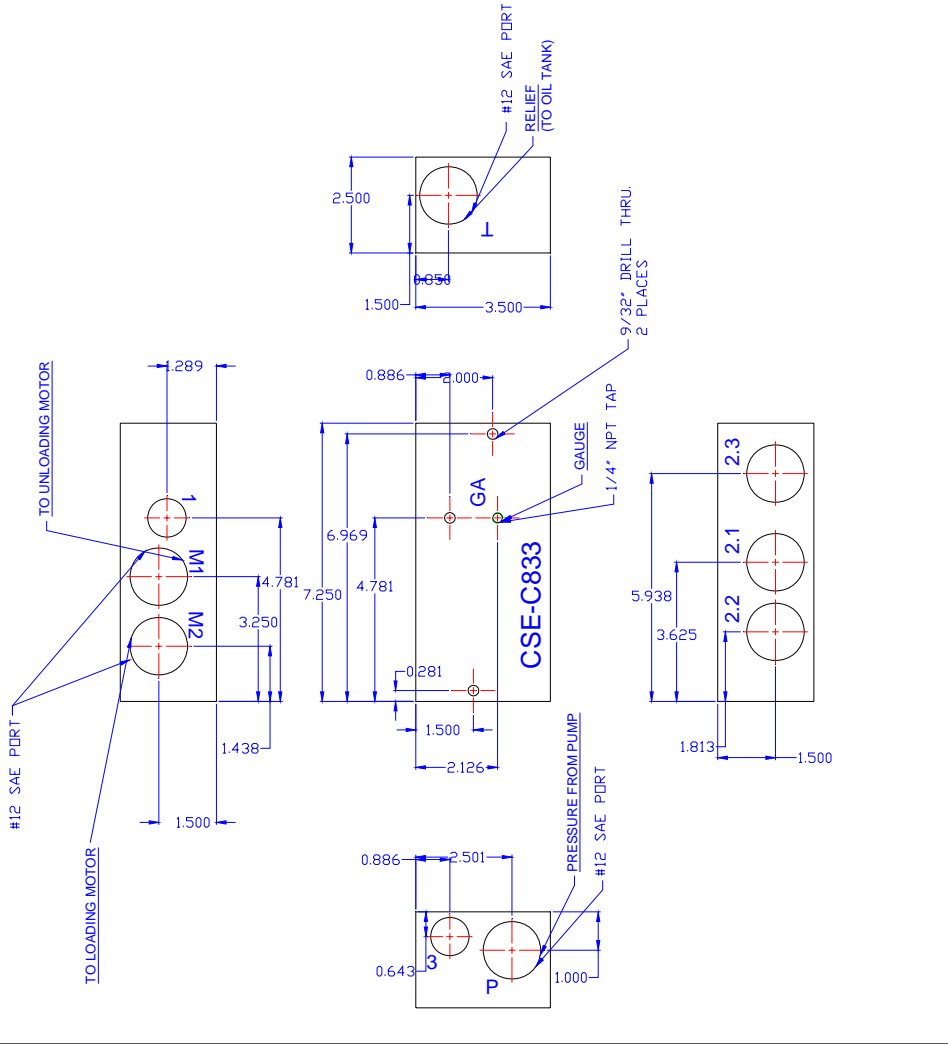

DO NOT SCALE DRAWING UNLESS OTHERWISE SPECIFIES DIMENSIONS ARE IN INCHES TOLERANCES ARE: FRACTIONAL: $\frac{1}{16}$ DECIMAL: _____ ANGLES: ± 2 DEGREE		CHECKED DATE R.M. 9-22-05
PROPRIETARY DRAWING This drawing cover a proprietary item and is the property of Lewis Brothers Manufacturing, INC.. This drawing in not to be copied or used without the approval of Lewis Brothers Manufacturing, INC..		APPROVED DATE
1 RV5-10-S-0-35/35, RELIEF EATON		
2.1 SV1-16-C-0-12DG, VALVE EATON		
2.2 SV1-16-C-0-12DG, VALVE EATON		
2.3 SV3-16-0-0-12DG, VALVE EATON		
3 SV5-8-0-12DGS, VALVE EATON		
--- MATERIAL		

Lewis Brothers Manufacturing, Inc.,
Baxley, Ga. - U.S.A.

Size A	Drawn	Drawing
Scale: None	RLM	9-12-05
1 0/1		

HK-101731 SINGLE SPOOL ELECTRIC VALVE